

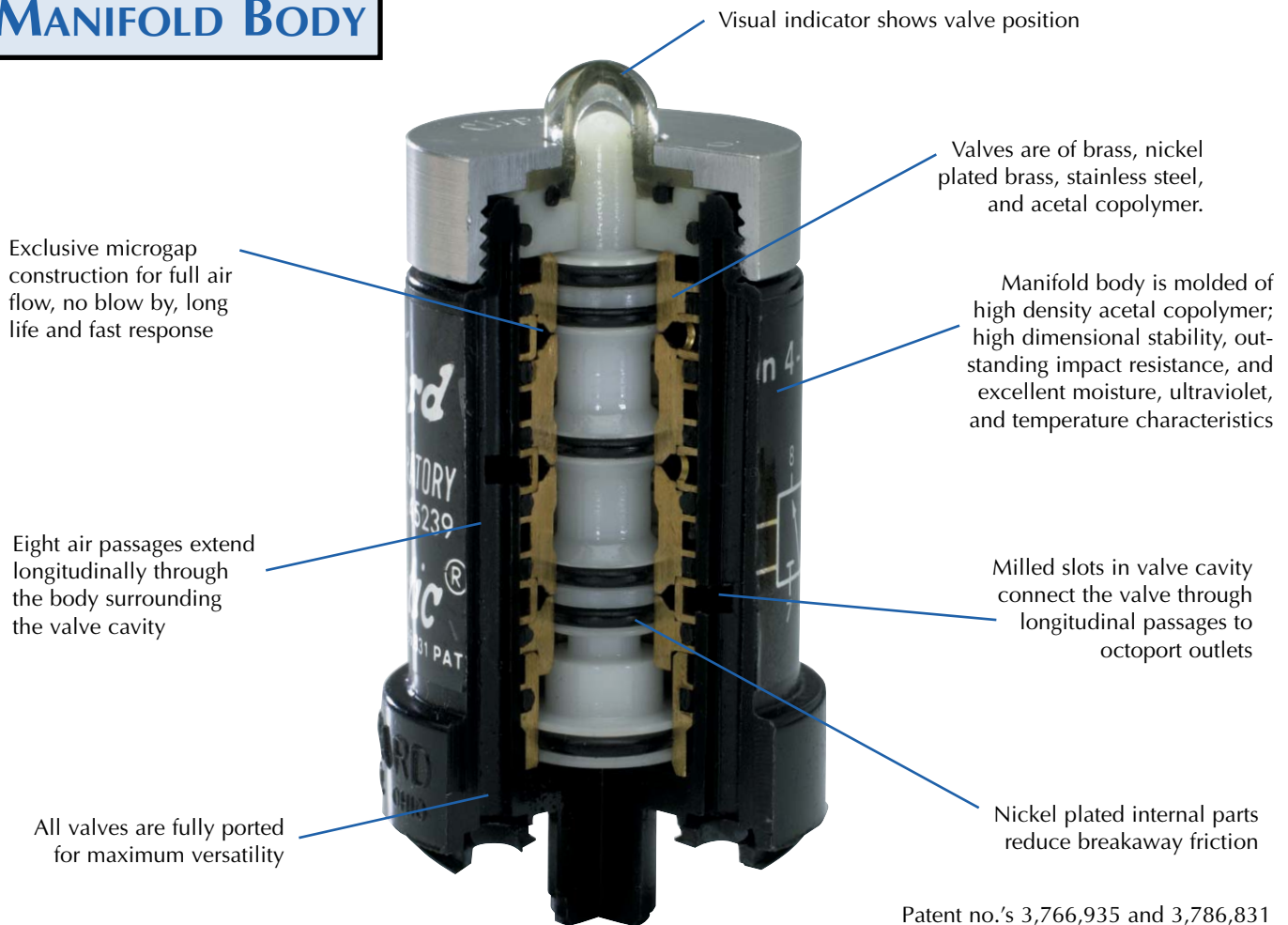

MODULAR VALVE SYSTEM

MANIFOLD BODY



Octoport Port Coding

The coding method shown here is used on the individual product catalog sheets. You will find a port usage diagram furnished for each variation of each model shown. Letters are used to identify port usage:

- S - Supply or Signal
- O - Output
- E - Exhaust
- P - Pilot Input

Where more than one supply, output, exhaust, etc. are involved in one module, subscript numerals are provided: S₁, S₂, etc. Where an auxiliary output is provided it may be identified by the letter O in parentheses: (O).

NOTE: Many of the Octoport valves have multiple ported supplies, outputs, or exhausts, etc. The port usage symbols will usually show one or the other of these ports with an "X" (must be plugged) in it. Both or either of the multiple ports may be used. Unused multiple ports must be plugged. The ANSI symbol will always show which valves have multiple ports.

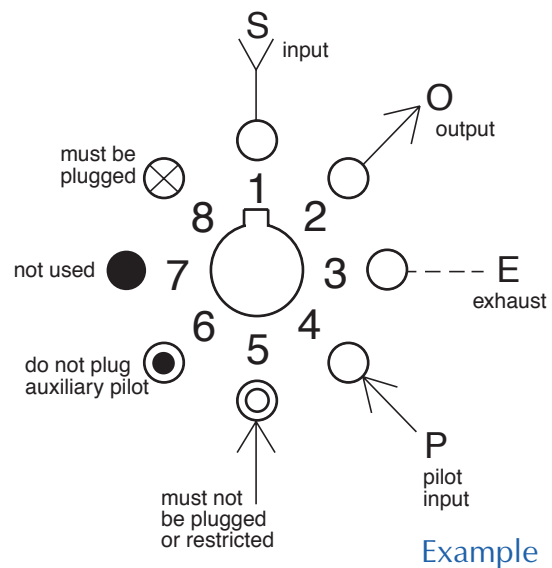

Base Valve

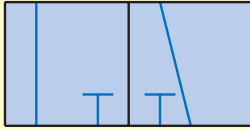

- Can be used as a:
- 2-way normally closed valve
 - 2-way normally open valve
 - 3-way normally closed valve
 - 3-way normally open valve
 - 3-way diverter valve
 - 3-way selector valve



- Can be used as a:
- 4-way fully ported valve
 - Dual 2-way valves (one N.O. & one N.C.)
 - Dual 3-way valves with common exhaust (one N.O. & one N.C.)

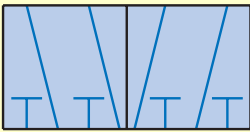

- Can be used as a:
- 6-way fully ported valve
 - Dual 2-way normally closed valve
 - Dual 2-way normally open valve
 - Dual 3-way normally closed valve
 - Dual 3-way normally open valve
 - Dual selector valve

Versatility is the key when it comes to Clippard's Minimatic® Modular Valves. Available in an unlimited variety of directional, flow, pressure and special control valves - each in a valve body designed to mount and link together with a simple piping system. The piping system eases assembly and plumbing, resulting in reduced labor costs, errors in installation, and the potential for plumbing leakage. In addition, multiple valve elements can be contained in a single body; providing incredible flexibility and variety to accomplish a myriad of control challenges. The Minimatic modular valves are the supreme "Plug and Play" devices for pneumatic applications.

Actuation Methods

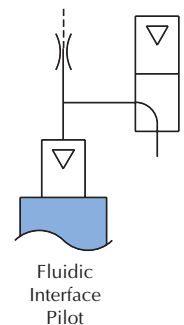
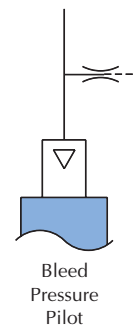
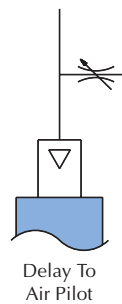
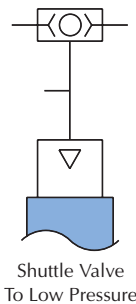
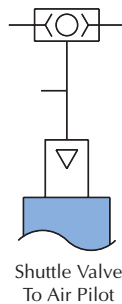
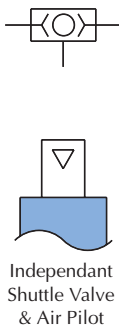
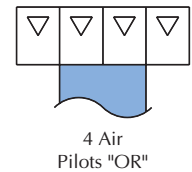
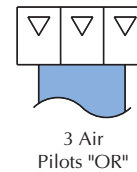
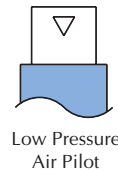
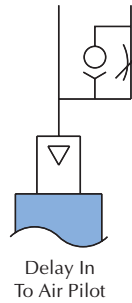
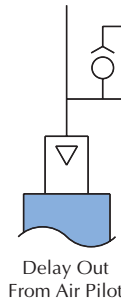
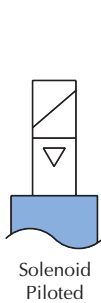
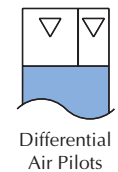
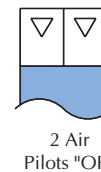
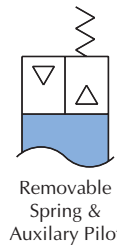
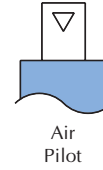



MODULAR VALVE SYSTEM

SIMPLIFIED ASSEMBLY

Screws and lockwashers (replacement part R-105) plated steel, binder head, #10-32 thread.



Molded gasket (replacement part R-104) furnished with each module.

Custom plastic manifold subplates of clear plastic have most interconnections inside; speed assembly, assure integrity of circuit. Valves plug in easily.



Standard mounting strips attach to interlocked subplates with #10-32 screws. Resulting circuit plate is rigid and strong. Modules plug in to circuit plate and are held by two fully captivated screws. Molded gasket provides seal between each module and subplate.

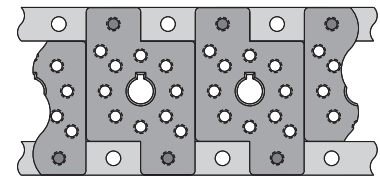
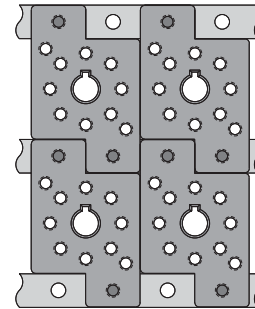
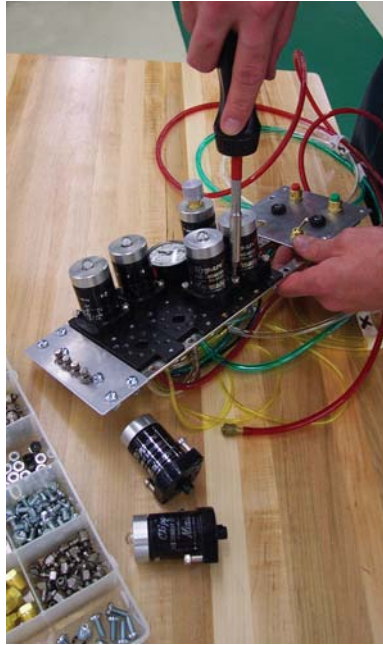

See [page 244](#) for further details.

Auxiliary Pilots

One of the bonus features of the Clippard Minimatic® modular components system is the availability and use of auxiliary pilots. These auxiliary pilots are included as standard on the following valves:

R-301	R-311	R-321	R-323	R-331	R-333
R-341	R-343	R-401	R-431	R-443	R-445
R-453	R-461	R-471	R-481		

All of these valves are air piloted with a spring return, with the added advantage of an auxiliary air pilot on the spring side of the valve. The auxiliary pilot consists of an air pilot in addition to the standard spring pilot. This feature greatly increases the versatility of the valve.

The auxiliary pilot may be used to cancel the force of the opposite pilot, thus enabling the spring to shift the valve, even though there is still air pressure on the opposite pilot (except R-431).

The majority of these valves will be used without the auxiliary pilot, but the ANSI symbols and port usage drawings show the auxiliary pilot.

Octoport Stamp

Part number R-108
Complete pneumatic circuit drawings in minimum time with this small, self inked octoport stamp.



System Requirements

The Clippard Minimatic® modular components system is designed to operate on standard shop air. The air supply should be reasonably clean and dry for optimum performance. The system operating range is 0 to 150 psig. Recommended filtration is 40 micron. Many units have pilot pressure requirements of 20 to 40 psig, therefore, system pressure should be sufficient to assure 40 psig as the absolute minimum pilot pressure at all times. A normal system operating pressure from 60 to 100 psig should adequately provide this. The system operates in a temperature range of 32 to 230°F.

NOTE: Constant operation at temperature range extremes may affect system performance.

Manifold Module Dimensions

Module manifold body is injection molded high density acetal copolymer for high dimensional stability, outstanding impact resistance, and excellent moisture, ultraviolet, and temperature characteristics.

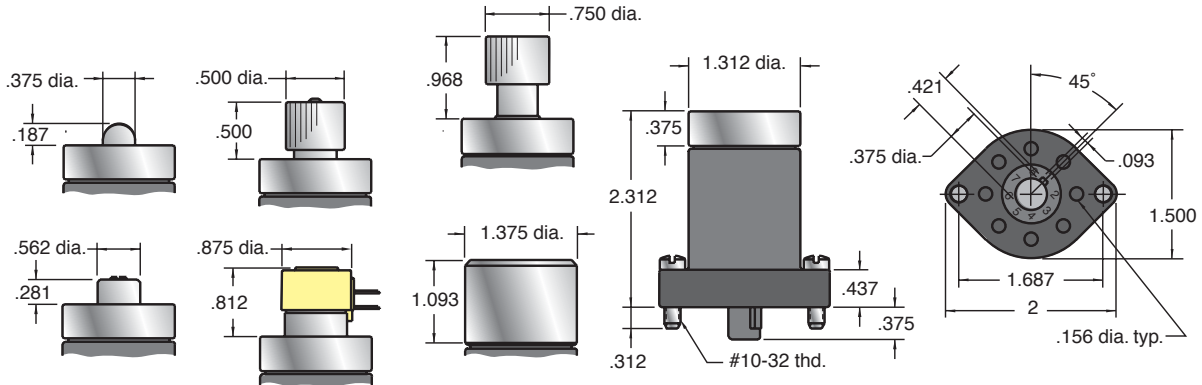

Subplate Dimensions

R-101/R-101-M5 subplate mounts to mounting strips with #10-32 screws and lockwashers provided. Ports on module base are numbered in the same pattern as on the subplate, making piping easy to identify. Module stem is keyed to fit center hole in subplate; assures fast insertion and proper positioning.

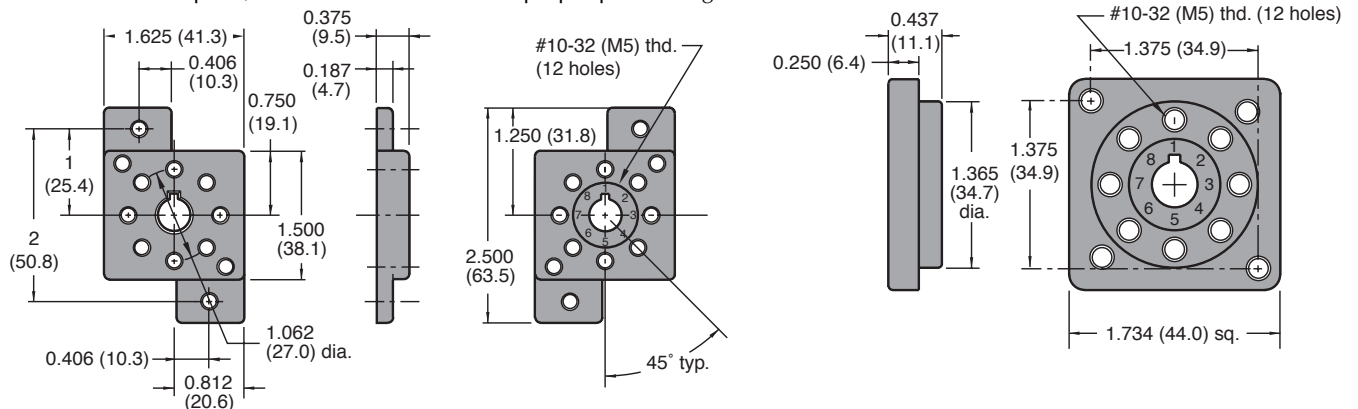

R-101 & R-101-M5 (metric)

R-111 & R-111-M5 (metric)

R-111/R-111-M5 subplate mounts in 1 3/8" (34.9) hole in electrical box, control panel. Mounting screws and gasket provided seal subplate to mounting plate.

Mounting Strips & Stand-Off Dimensions

R-107-20

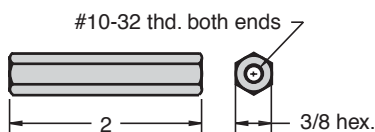

For providing space beneath assembled group of modules, use R-106 (order R-107-20, packet of four with hardware). Provides 2" clearance from enclosure wall for piping with Clippard fittings and tubing. Keeps piping and installation neat.

When subplates are mounted to mounting strips, the components build into a strong, rigid assembly. Because of extra tolerance in the holes, note that strips may be adjusted before screws are fully tightened. This permits accurate alignment of subplates. The identifying number following the second dash in the part number indicates the number of modules the strip will accommodate while still proving a short extension with one hole at both ends for using in mounting the assembly to stand-offs or other structures. The strip will accommodate 1 additional module if no extensions for mounting are needed. (Every two holes will accept a subplate.)

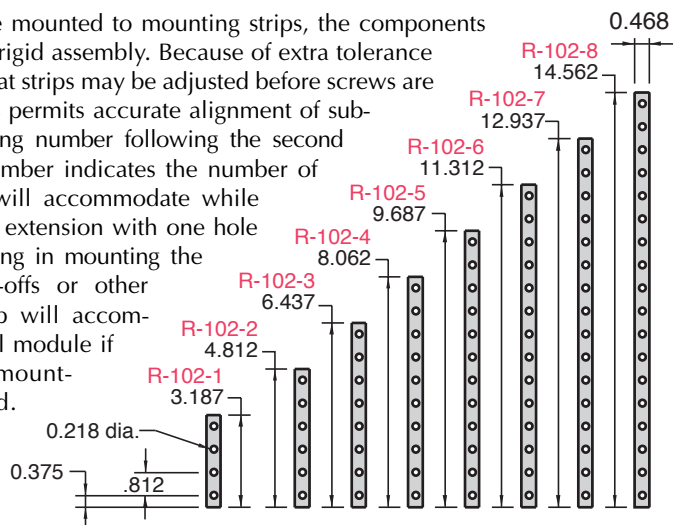

STEP ONE

Pneumatic Circuit

The first step in building a modular circuit is designing the pneumatic circuit using ANSI symbols.

Starting on [page 273](#) we have a number of circuits utilizing Clippard Minimatic Modular Components. We have chosen the Two Hand No Tie Down Circuit for this demonstration.

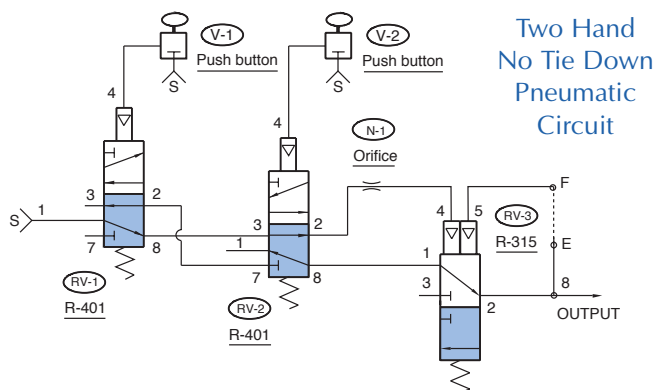

STEP TWO

Specifications for the [R-315](#) modular valve

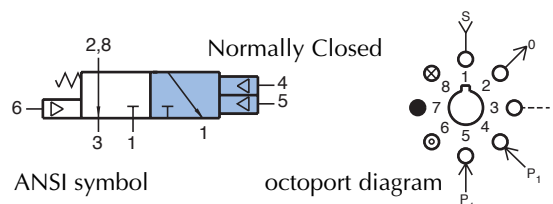

Octoport Diagrams

The next step is selecting the octoport diagram for each modular valve. Each Clippard modular valve (R-series) has its own unique octoport diagram which is shown to the right of the ANSI symbol.

See page 240 for clues for deciphering the Octoport port coding.

STEP THREE

Components for Modular Circuit

Next, you need to gather the required components. Typically, the modular portion of a circuit consists of modular valves, subplates, mounting strips, 1/16" and 1/8" fittings, 1/16" and 1/8" hose, and the main air supply connect fitting.

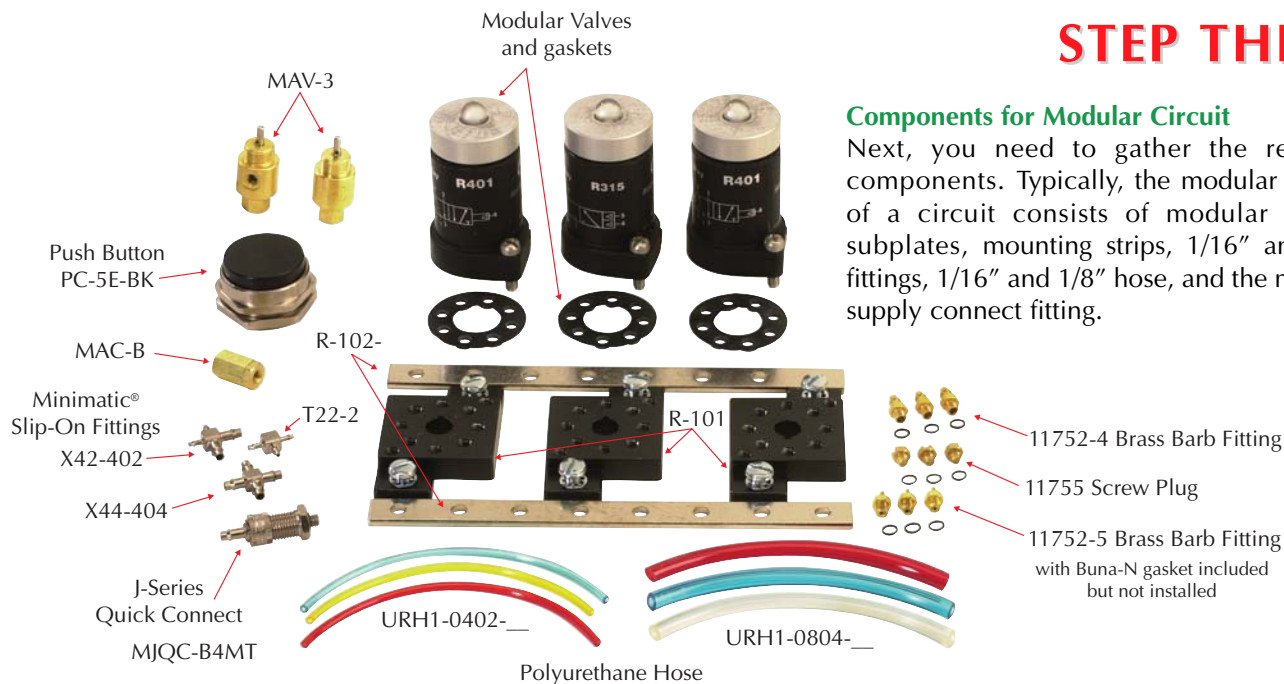

STEP FOUR

Mounting Strip and Subplate Assembly

The next step is assembling the mounting strips (R-102-) and subplates (R-101/R-101-M5).

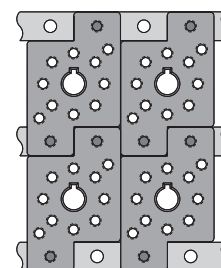
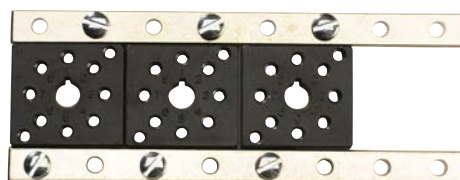

Possible configurations for subplates

Subplate and Fitting Installation

The next step is to install the fittings into the R-101/R-101-M5 subplates using the octoport, octoport port coding, and pneumatic circuit diagrams. Generally, 1/16" hose is used for pilot ports and their adjoining lines and 1/8" hose are for supply lines and cylinders.

Looking at the two hand no tie down circuit:

1. Valve RV-1 has fitting 11752-5 (#10-32 to 1/16" ID hose fitting) installed in ports 4 and 8
2. Fitting 1752-4 (#10-32 thd. to 1/8" ID hose fitting) installed in ports 1 and 2 because port 1 is the main air supply for the circuit and port 2 is the outlet.
3. On valves V-1 and V-2, fitting 11752-5 was installed in both the inlet and outlet of each valve because both valves are used for pilot actuation of valves RV-1 and RV-2.

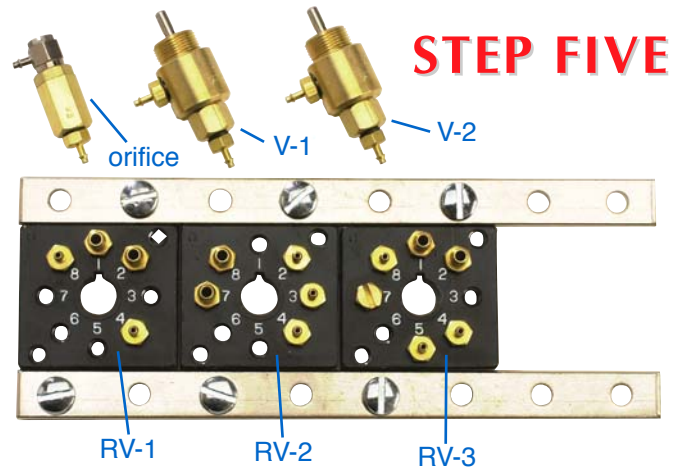

4. Being in a pilot line, the inline fixed orifice air choke N-1 was fitted with an 11752-5 on one end and a UTO-2 universal "L" fitting on the other.

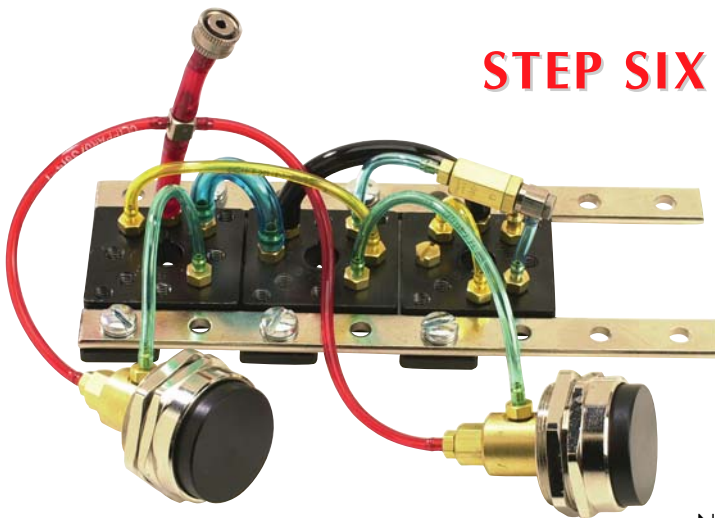

Connecting Hose

With the fittings installed, the circuit is ready for hose. The color coding we use at Clippard is quite simple. Red hose is used for all supply lines. For all other hose as many different colors as possible are used in order to facilitate circuit trouble shooting.

1. Supply lines - Red hose
2. The 1/16" ID fittings require URH1-0402 hose
3. The 1/8" ID fittings require URH1-0804 hose
4. The main supply line was fitted with a MJQC-CB4 which can be attached to any of the MJQC valve bodies.

Note: The MJQC series is not compatible with the MQC series.

STEP SEVEN

Modular Valve Hook-Up

The final assembly step is installing the modular valves and mounting gasket to the subplates.

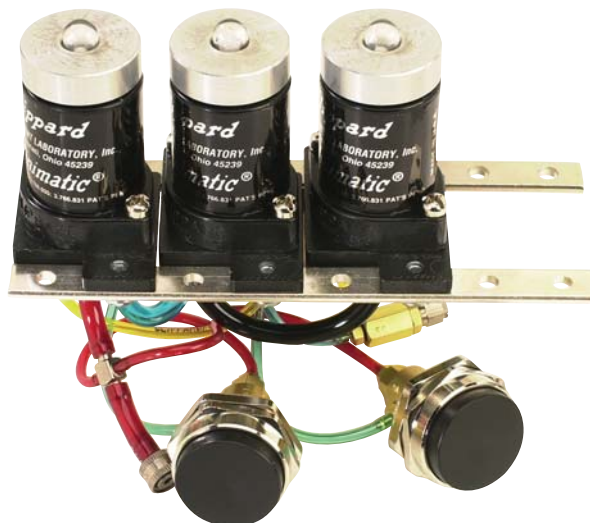

Hose and barb sizes were picked with this particular application in mind. Both may vary to meet your needs. Feel free to contact our facility for technical support.



MODULAR 3-WAY VALVE

R-301



3-Way Valve

Features:

- Indicator shows valve in shaded position
- Multiple porting speeds piping
- Micro gap construction - snap action and no blow by
- Balanced design allows speed control at exhausts

Performance:

Flow: 9 scfm @ 100 psig; 255 l/min @ 6.9 bars
Pilot Pressure Minimum: 40 psig; 2.8 bars
Temperature: 32° to 180° F
Working Pressure: Vacuum to 150 psig; 10.3 bars

Description:

R-301 is a 3-way, spring return, fully ported, piloted valve. It can be used normally-OPEN, normally-CLOSED, as a diverter or as a selector. It can also be used as a 2-way valve by plugging the exhaust ports.

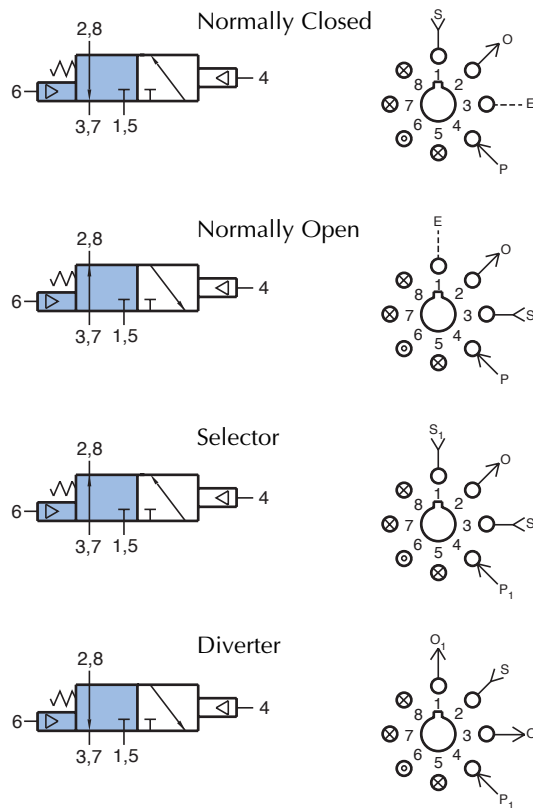

R-302



3-Way Valve

Features:

- Indicator shows valve in shaded position
- Multiple porting speeds piping
- Micro gap construction - snap action and no blow by
- Balanced design allows speed control at exhausts

Performance:

Flow: 9 scfm @ 100 psig; 255 l/min @ 6.9 bars
Pilot Pressure Minimum: 20 psig; 1.4 bars
Temperature: 32° to 180° F
Working Pressure: 0 to 150 psig; 0 to 10.3 bars

Description:

R-302 is a 2-position, 3-way, double-piloted, fully-ported valve. It can be used normally-OPEN, normally-CLOSED, as a 2-position diverter, as a 2-position selector, or as a 2-way valve by plugging the exhaust ports.

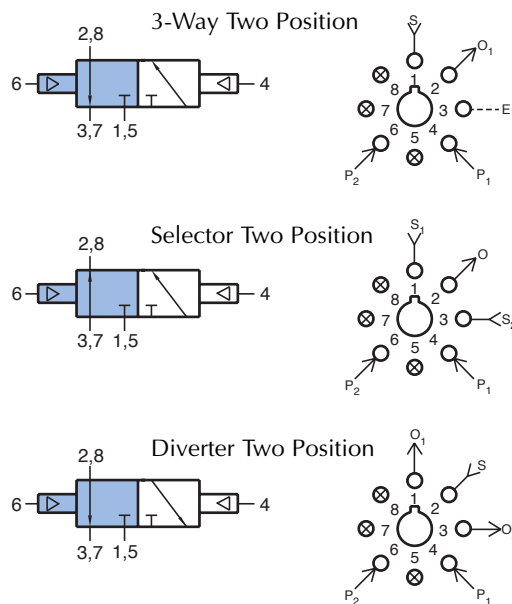

R-305



3-Way Low Pressure Pilot Valve

Features:

- Pilot actuates valve with low pressure signal
- Multiple porting speeds piping
- Micro gap construction - snap action and no blow by
- Balanced design allows speed control at exhausts

Performance:

Flow: 9 scfm @ 100 psig; 255 l/min @ 6.9 bars
Pilot Pressure Minimum: 15 psig; 1.0 bars
Temperature: 32° to 180° F
Working Pressure: 0 to 150 psig; 0 to 10.3 bars

Description:

R-305 is a 3-way, spring-return, fully ported valve with a low pressure pilot. Pilot pressure signals as low as 15 psig will actuate the valve. The valve can be used normally-OPEN, normally-CLOSED, as a selector or as a diverter. The R-305 may be used in place of an R-301 valve where a lower pilot actuation pressure is desired. It can also be used as a 2-way valve by plugging the exhaust ports.

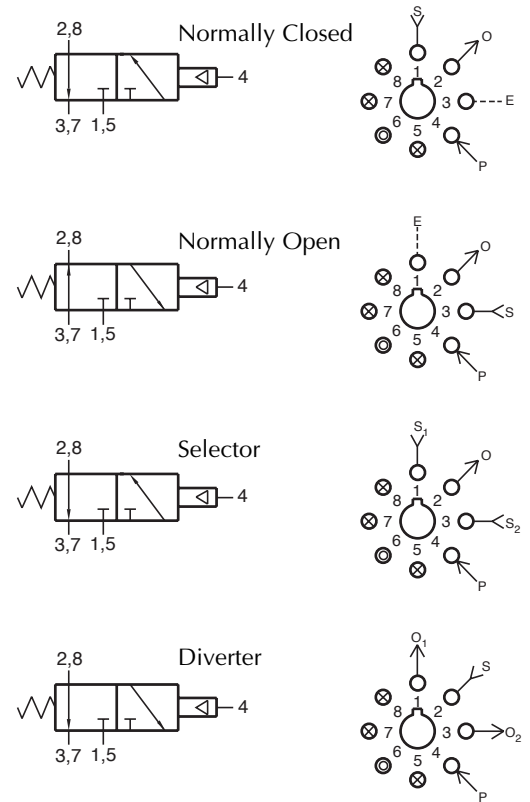

R-310



3-Way Reset Valve

Features:

- Indicator shows valve in shaded position
- Multiple porting speeds piping
- Micro gap construction - snap action and no blow by
- Balanced design allows speed control at exhausts
- Unique piloted spring reset

Performance:

Flow: 9 scfm @ 100 psig; 255 l/min @ 6.9 bars
Pilot Pressure Minimum (against spring): 40 psig; 2.8 bars
Pilot Pressure Minimum (spring retracted): 20 psig; 1.4 bars
Temperature: 32° to 180° F
Working Pressure: 0 to 150 psig; 0 to 10.3 bars

Description:

R-310 is a 3-way, fully ported valve with a special air retracted spring return that will return the valve to a definite position when there is no signal at ports 5 and 4. This "reset" feature may be used in circuits in the event of air pressure or to change the operating characteristics of the valve in the circuit in response to an independent input at port 5. When port 5 is not piloted, the R-310 acts as an R-301 3-way spring return, fully ported valve. When port 5 is actuated, the R-310 acts as an R-302 3-way, two position valve. With no signal at port 5, a signal at port 6 acts as an auxiliary pilot type valve and will override a signal at port 4.

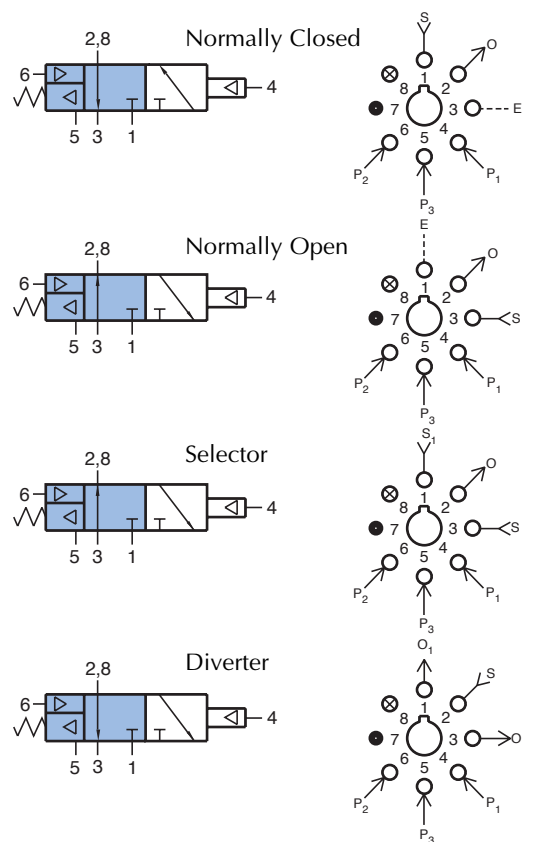



MODULAR 3-WAY VALVES

R-311



Description:

R-311 is a 3-way, spring return, fully ported valve with four pilots. Any one of the four pilots will actuate the valve. Actuating more than one pilot has no additional effect. Pilot signals must be absent at all four pilots to release the valve. The valve can be used normally - OPEN, normally - CLOSED, as a selector or as a diverter, all with four pilot inputs. It can also be used as a 2-way valve by plugging the exhaust ports. The R-311 may be used to replace an R-301 or R-321 valve in a circuit when additional pilot inputs are required. The R-311 also features an auxiliary pilot on the spring side of the valve. The auxiliary pilot will overcome any one or all of the four input pilots.

3-Way Multiple Pilot Valve

Features:

- Indicator shows valve in shaded position
- Multiple pilots reduces number of valves - reduces piping and space required
- Micro gap construction - snap action and no blow by
- Balanced design allows speed control at exhaust

Performance:

Flow: 9 scfm @ 100 psig; 255 l/min @ 6.9 bars

Pilot Pressure Minimum: 40 psig; 2.8 bars

Temperature: 32° to 180° F

Working Pressure: 0 to 150 psig; 0 to 10.3 bars

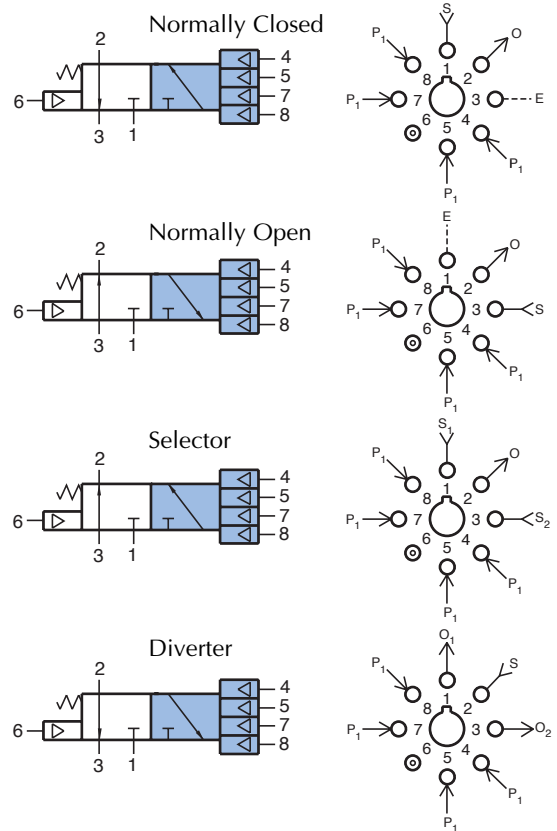

R-312



Description:

R-312 is a 3-way, two position, fully ported valve with four pilots on one position. Any one of the four pilots on one position will actuate the valve. Actuating more than one pilot has no additional effect. Pilot signals must be absent at all four pilots before the opposite pilot can shift the valve. The valve can be used normally-OPEN, normally-CLOSED, as a selector, or as a diverter, all with four pilot inputs. It can also be used as a 2-way valve by plugging the exhaust ports. The R-312 may be used to replace an R-302 or R-322 valve in a circuit when additional pilot inputs are required.

3-Way Multiple Pilot Valve

Features:

- Indicator shows valve in shaded position
- Multiple pilots reduces number of valves - reduces piping and space required
- Micro gap construction - snap action and no blow by
- Balanced design allows speed control at exhaust

Performance:

Flow: 9 scfm @ 100 psig; 255 l/min @ 6.9 bars

Pilot Pressure Minimum: 20 psig; 1.4 bars

Temperature: 32° to 180° F

Working Pressure: 0 to 150 psig; 0 to 10.3 bars

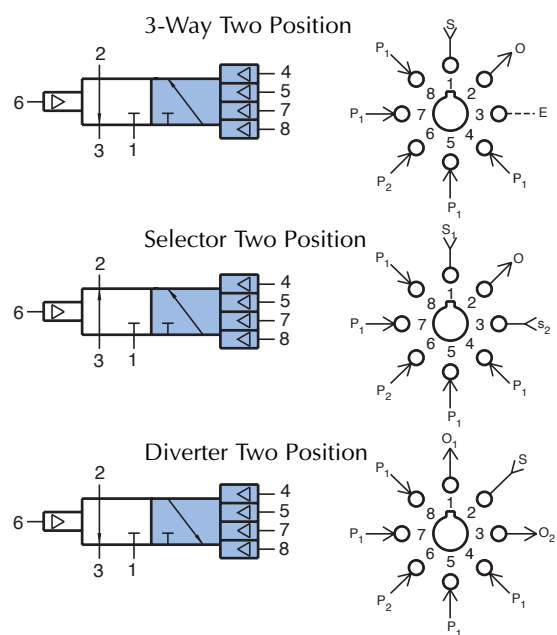

R-314



3-Way Multiple Pilot Valve

Features:

- Multiple pilots reduces number of valves - reduces piping and space required
- Micro gap construction - snap action and no blow by
- Balanced design allows speed control at exhausts

Performance:

Flow: 9 scfm @ 100 psig; 255 l/min @ 6.9 bars
Pilot Pressure Minimum: 20 psig; 1.4 bars
Temperature: 32° to 180° F
Working Pressure: 0 to 150 psig; 0 to 10.3 bars

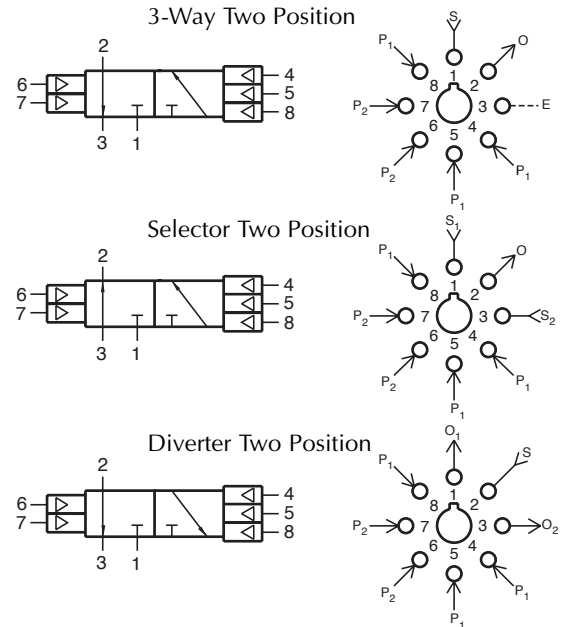

Description:

R-314 is a 3-way, air piloted, two position valve. It has three pilots on one side and two pilots on the other side. (see symbol) Actuating more than one pilot on the same side has no additional effect. Pilot signals must be absent from all pilots (on the same side) before an opposite pilot will shift the valve. The valve can be used normally-OPEN, normally-CLOSED; as a selector, or as a diverter. It may be used as a 2-way valve by plugging the exhaust ports.

R-315



3-Way Multiple Pilot Valve

Features:

- Indicator shows valve in shaded position
- Multiple pilots reduces number of valves - reduces piping and space required
- Micro gap construction - snap action and no blow by
- Balanced design allows speed control at exhaust

Performance:

Flow: 9 scfm @ 100 psig; 255 l/min @ 6.9 bars
Pilot Pressure Minimum: 40 psig; 2.8 bars
Temperature: 32° to 180° F
Working Pressure: 0 to 150 psig; 0 to 10.3 bars

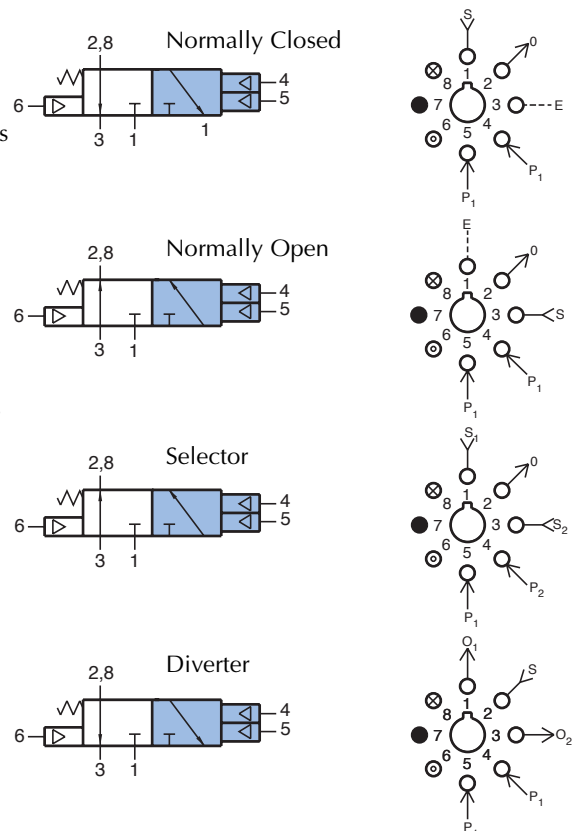

Description:

R-315 is a 3-way, spring return, fully ported valve with two independent pilots that make it ideal for "latch" circuits. Either of the two pilots will actuate the valve. Actuating more than one pilot has no additional effect. Pilot signals must be absent at both pilots to release the valve. The valve can be used normally-OPEN, normally-CLOSED, as a selector or as a diverter. It can also be used as a 2-way valve by plugging the exhaust ports. The R-315 may be used to replace an R-301 valve in a circuit when additional pilot inputs are required. The R-315 also features an auxiliary pilot on the spring side of the valve. The auxiliary pilot will overcome any one or all of the four input pilots.



MODULAR 3-WAY COMBINATION VALVES

R-321



3-Way Combination Valve

Features:

- Indicator shows valve in shaded position
- Multiple porting speeds piping
- Micro gap construction - snap action and no blow by
- Balanced design allows speed control at exhausts

Performance:

Flow: 9 scfm @ 100 psig; 255 l/min @ 6.9 bars
Pilot Pressure Minimum: 40 psig; 2.8 bars
Temperature: 32° to 180° F
Working Pressure: 0 to 150 psig; 0 to 10.3 bars

Description:

R-321 is a 3-way, spring return, fully ported valve with an interconnected shuttle valve in one pilot line to provide two inputs to the pilot. It can be used normally - OPEN, normally - CLOSED, as a diverter, or as a selector. Auxiliary outlet is provided through port 7, which should be plugged if not used.

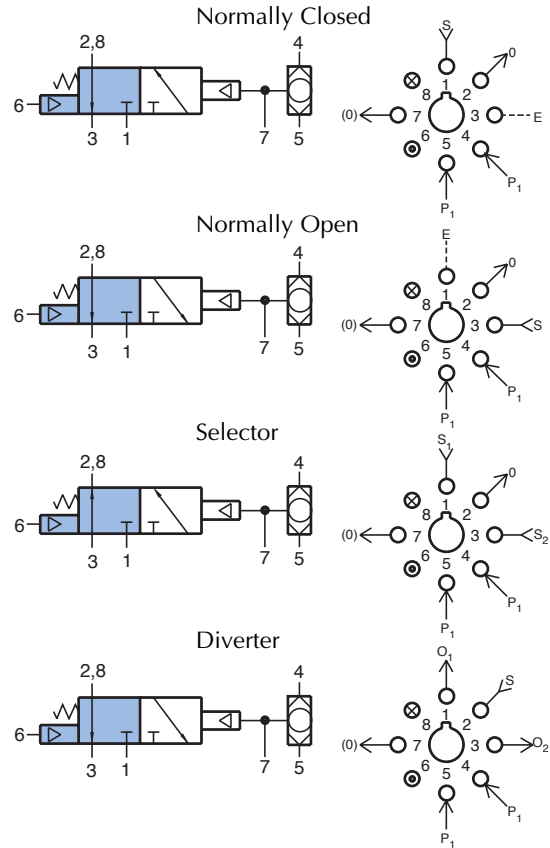

R-322



3-Way Combination Valve

Features:

- Indicator shows valve in shaded position
- Multiple porting speeds piping
- Micro gap construction - snap action and no blow by
- Balanced design allows speed control at exhausts

Performance:

Flow: 9 scfm @ 100 psig; 255 l/min @ 6.9 bars
Pilot Pressure Minimum: 20 psig; 1.4 bars
Temperature: 32° to 180° F
Working Pressure: 0 to 150 psig; 0 to 10.3 bars

Description:

R-322 is a 3-way valve, 2-position, fully ported, with an interconnected shuttle valve in one pilot line to provide two inputs to the pilot. It can be normally-OPEN, normally-CLOSED, as a 2-position selector, or as a 2-position diverter. Auxiliary outlet is provided through port 7, which should be plugged if not used.

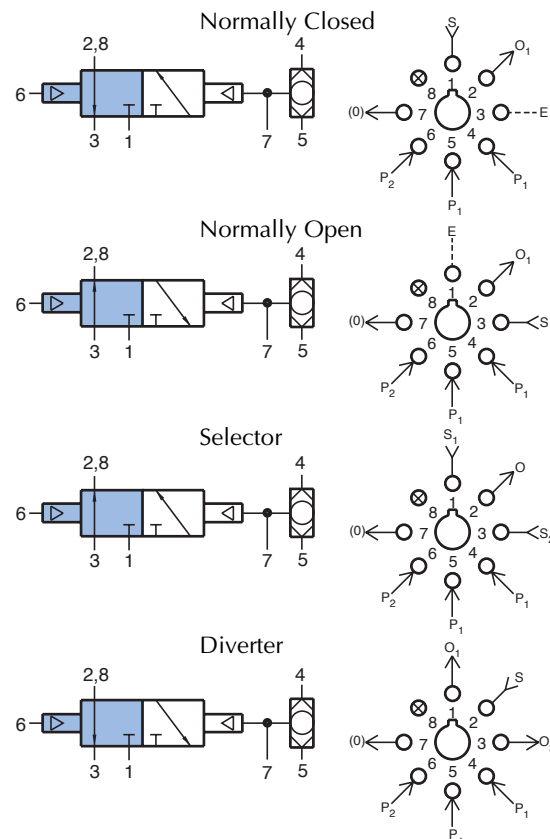

R-323



3-Way Combination Valve

Features:

- Indicator shows valve in shaded position
- Multiple valves save space
- Micro gap construction - snap action and no blow by
- Balanced design allows speed control at exhausts

Performance:

Flow: 9 scfm @ 100 psig; 255 l/min @ 6.9 bars
Pilot Pressure Minimum: 40 psig; 2.8 bars
Temperature: 32° to 180° F
Working Pressure: 0 to 150 psig; 0 to 10.3 bars

Description:

R-323 is a 3-way, spring return, fully ported valve with an independent shuttle valve in the same body. Both valves may be used independently in a circuit. The 3-way can be used normally-OPEN, normally-CLOSED; as a diverter, or as a selector. The R-323 also features an auxiliary pilot on the spring side of the valve.

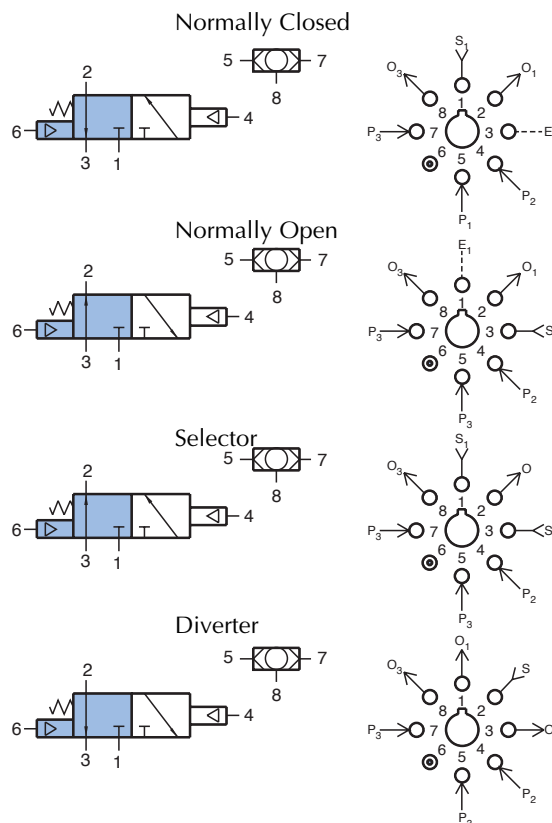

R-324



3-Way Combination Valve

Features:

- Indicator shows valve in shaded position
- Multiple valves save space
- Micro gap construction - snap action and no blow by
- Balanced design allows speed control at exhausts

Performance:

Flow: 9 scfm @ 100 psig; 255 l/min @ 6.9 bars
Pilot Pressure Minimum: 20 psig; 1.4 bars
Temperature: 32° to 180° F
Working Pressure: 0 to 150 psig; 0 to 10.3 bars

Description:

R-324 is a 3-way, two position, fully ported valve with an independent shuttle valve in the same body. Both valves may be used independently in a circuit. The 3-way can be used normally-OPEN, normally-CLOSED; as a diverter, or as a selector.

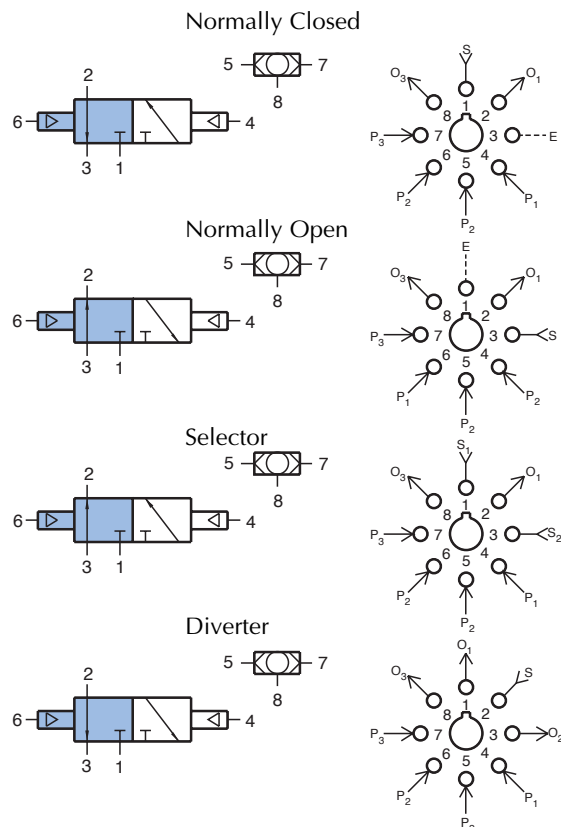



MODULAR 3-WAY COMBINATION VALVES

R-325



3-Way Low Pressure Combination Valve

Features:

- Pilot actuates valve with low pressure signal
- Multiple porting speeds piping
- Micro gap construction - snap action and no blow by
- Balanced design allows speed control at exhausts

Performance:

Flow: 9 scfm @ 100 psig; 255 l/min @ 6.9 bars

Pilot Pressure Minimum: 15 psig; 1.0 bar

Temperature: 32° to 180° F

Working Pressure: 0 to 150 psig; 0 to 10.3 bars

Description:

R-325 is a 3-way, spring return, fully ported valve with a low pressure pilot and an interconnected shuttle valve to provide two inputs to the low pressure pilot. It can be used normally - CLOSED, normally - OPEN, as a 2-position diverter, or as a 2-position selector. The R-325 may be used in place of an R-321 valve where a lower pilot pressure is desired. Auxiliary outlet is provided through port 7, which should be plugged if not used.

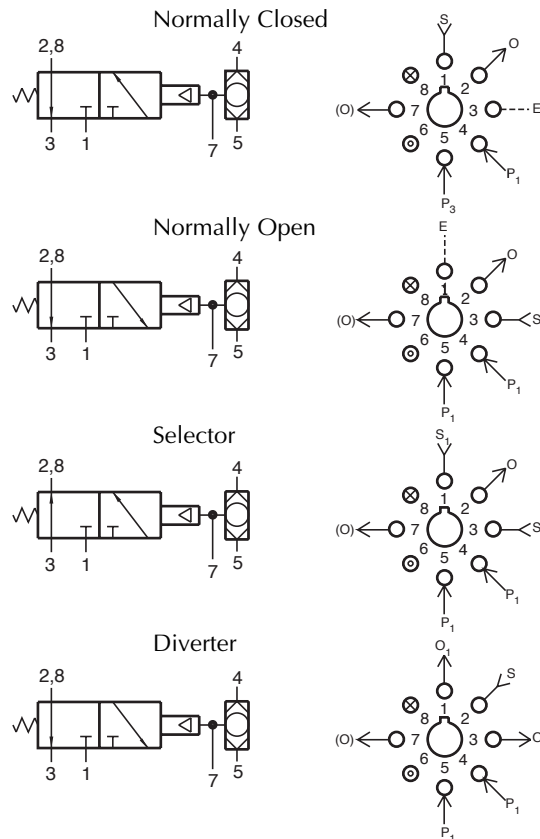

R-331 R-333



3-Way Delay Valve

Features:

- Multiple porting speeds piping
- Micro gap construction - snap action and no blow by
- Screwdriver slot needle adjustment deters tampering (R-333)
- Knurled knob for fast accurate adjustments - no tools needed (R-331)
- 0-5 seconds range

Performance:

Flow: 9 scfm @ 100 psig; 255 l/min @ 6.9 bars

Pilot Pressure Minimum: 40 psig; 2.8 bars

Temperature: 32° to 180° F

Working Pressure: 0 to 150 psig; 0 to 10.3 bars

Description:

R-331 and R-333 are dual element combinations consisting of a fully ported, spring return, 3-way valve, and an adjustable flow control to provide a delay "IN" function. Input signal at port 4 will be delayed through adjustable flow control and will delay the actuation of the valve. The 3-way valve is fully ported and can be used normally-OPEN, normally-CLOSED, or as a selector or diverter. Port 7 is an auxiliary for adding volume for longer time delays. If not used, port 7 should be plugged.

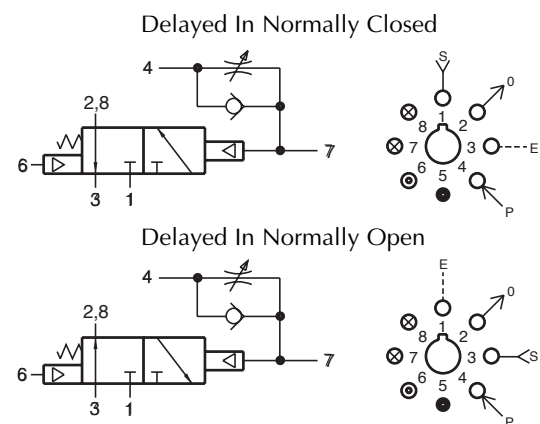

R-332 R-334



3-Way Delay Valve

Features:

- Multiple porting speeds piping
- Micro gap construction - snap action and no blow by
- Screwdriver slot needle adjustment deters tampering (R-334)
- Knurled knob for fast accurate adjustments - no tools needed (R-332)
- 0-3 seconds range

Performance:

Flow: 9 scfm @ 100 psig; 255 l/min @ 6.9 bars
Pilot Pressure Minimum: 20 psig; 1.4 bars
Temperature: 32° to 180° F
Working Pressure: 0 to 150 psig; 0 to 10.3 bars

Description:

R-332 and R-334 are dual element combinations consisting of a 2-position, 3-way valve, fully ported, and an adjustable flow control to provide a delay "IN" function. Input signal at port 4 will be delayed through adjustable flow control and will delay the actuation of the valve. The 3-way valve can be used normally-OPEN, normally-CLOSED, as a 2-position selector or 2-position diverter. Port 7 is an auxiliary for adding volume for longer time delays. If not used, port 7 should be plugged.

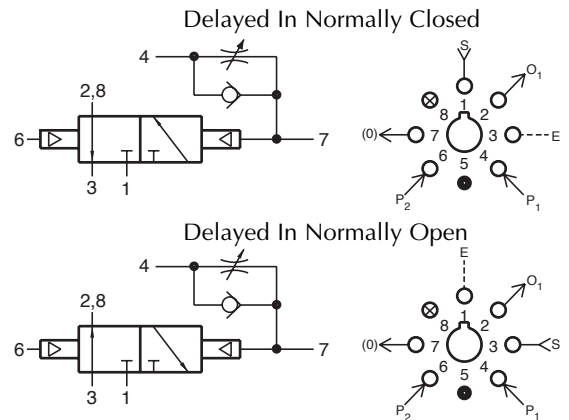

R-341 R-343



3-Way Delay Valve

Features:

- Multiple porting speeds piping
- Micro gap construction - snap action and no blow by
- Screwdriver slot needle adjustment deters tampering (R-343)
- Knurled knob for fast accurate adjustments - no tools needed (R-341)
- 0-7 seconds range

Performance:

Flow: 9 scfm @ 100 psig; 255 l/min @ 6.9 bars
Pilot Pressure Minimum: 40 psig; 2.8 bars
Temperature: 32° to 180° F
Working Pressure: 0 to 150 psig; 0 to 10.3 bars

Description:

R-341 and R-343 are dual element combinations consisting of a fully ported spring return, 3-way valve and an adjustable flow control to provide a delay "out" function. Input signal at port 4 actuates the valve immediately; and upon loss of pressure signal at port 4, the valve remains in position until pilot pressure decays through the flow control. The valve can be used as normally - OPEN or normally-CLOSED, and as a diverter or selector. Port 7 is an auxiliary for adding volume for longer time delays. If not used, port 7 should be plugged.

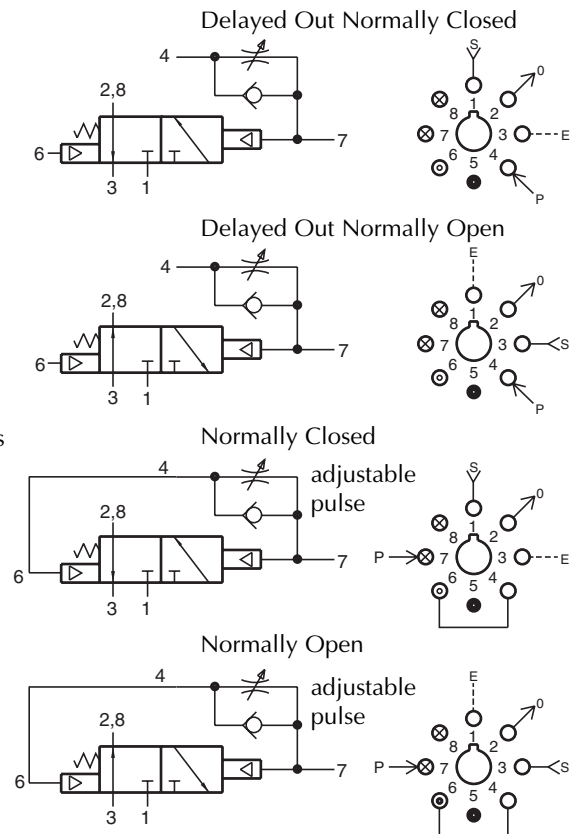



MODULAR MULTIPLE 3-WAY VALVES

R-351

Dual Normally Closed 3-Way Valve

Features:

- Micro gap construction - snap action and no blow by
- Two independent valves in one module
- Saves space

Performance:

Flow: 9 scfm @ 100 psig; 255 l/min @ 6.9 bars
Pilot Pressure Minimum: 40 psig; 2.8 bars
Temperature: 32 to 180° F
Working Pressure: 0 to 150 psig; 0 to 10.3 bars

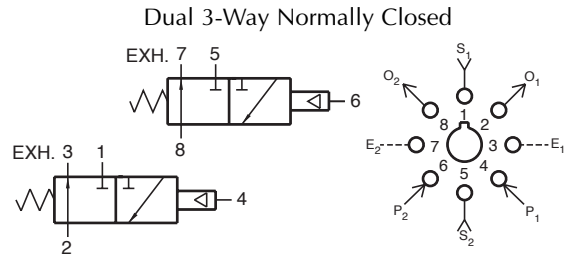

Description:

R-351 is a dual element combination of 2 independent, spring return, 3-way valves in a single manifold, set-up for normally-CLOSED usage only. Ports 3 and 7 are exhausts to atmosphere and cannot be restricted.

R-352

Dual 3-Way Valve

Features:

- Micro gap construction - snap action and no blow by
- Two independent units in one module
- Common supply eliminates extra piping

Performance:

Flow: 9 scfm @ 100 psig; 255 l/min @ 6.9 bars
Pilot Pressure Minimum: 40 psig; 2.8 bars
Temperature: 32° to 180° F
Working Pressure: 0 to 150 psig; 0 to 10.3 bars

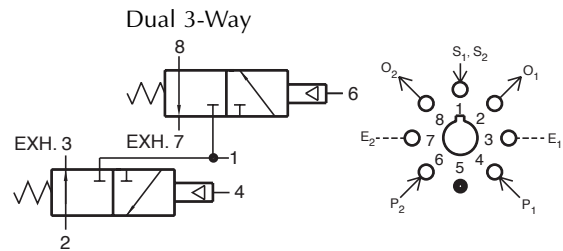

Description:

R-352 is a dual element combination consisting of 2 independent, spring return, 3-way normally-CLOSED valves with a common inlet. Ports 3 and 7 are exhausts to atmosphere, and can not be restricted.

R-353



Dual 3-Way Valve

Features:

- Micro gap construction - snap action and no blow by
- Complete function in one module
- Auxiliary outputs save fittings and time

Performance:

Flow: 9 scfm @ 100 psig; 255 l/min @ 6.9 bars

Pilot Pressure Minimum: 40 psig; 2.8 bars

Temperature: 32° to 180° F

Working Pressure: 0 to 150 psig; 0 to 10.3 bars

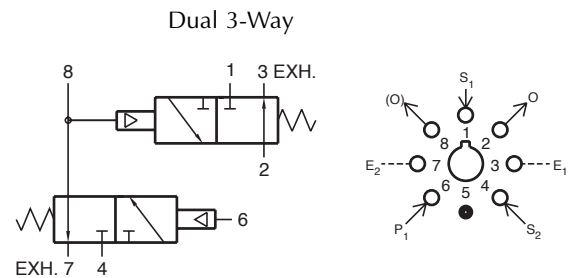

Description:

R-353 is a dual element combination consisting of 2 normally-CLOSED, spring return, 3-way valves interconnected to form a 3-input "AND" subcircuit. Ports 3 and 7 are exhausted to atmosphere, and should not be restricted. Ports 1, 4, and 6 are inputs. Output will occur at Port 2 only when all three of these ports are actuated. Port 8 is an auxiliary output and should be plugged if not used.

R-355



Dual Normally Open 3-Way Valve

Features:

- Micro gap construction - snap action and no blow by
- Two independent units in one module
- Saves space

Performance:

Flow: 9 scfm @ 100 psig; 255 l/min @ 6.9 bars

Pilot Pressure Minimum: 40 psig; 2.8 bars

Temperature: 32° to 180° F

Working Pressure: 0 to 150 psig; 0 to 10.3 bars

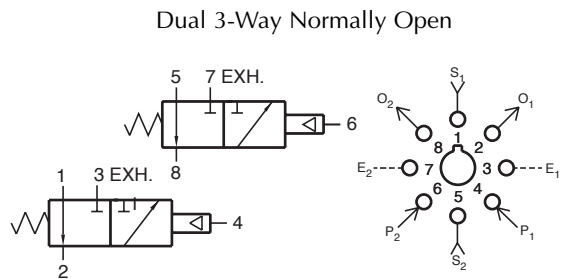

Description:

R-355 is a dual element combination of 2 independent, spring-return, 3-way valves in a single manifold, set-up for normally-OPEN usage only. Ports 3 and 7 are exhausts to atmosphere and can not be restricted.



MODULAR 4-WAY VALVES

R-401



4-Way Valve

Features:

- Indicator shows valve in shaded position
- Micro gap construction - snap action and no blow by
- Balanced design allows speed control at exhausts

Performance:

Flow: 9 scfm @ 100 psig; 255 l/min @ 6.9 bars
Pilot Pressure Minimum: 40 psig; 2.8 bars
Temperature: 32° to 180° F
Working Pressure: 0 to 150 psig; 0 to 10.3 bars

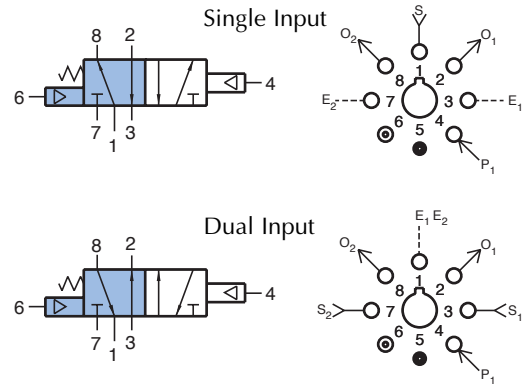

Description:

R-401 is a 4-way, spring return, pilot operated, fully ported 5-ported 4-way valve. R-401 is a versatile component in basic logic circuits, and can perform all 2, 3, and 4-way functions. Operates double acting cylinders, and allows speed control by restricting exhaust ports. It can be used with one input, two independent outputs and two independent exhausts, or with two independent inputs, two independent outputs and a common exhaust. Auxiliary pilot feature.

R-402



4-Way Valve

Features:

- Indicator shows valve in shaded position
- Micro gap construction - snap action and no blow by
- Balanced design allows speed control at exhausts

Performance:

Flow: 9 scfm @ 100 psig; 255 l/min @ 6.9 bars
Pilot Pressure Minimum: 20 psig; 1.4 bars
Temperature: 32° to 180° F
Working Pressure: 0 to 150 psig; 0 to 10.3 bars

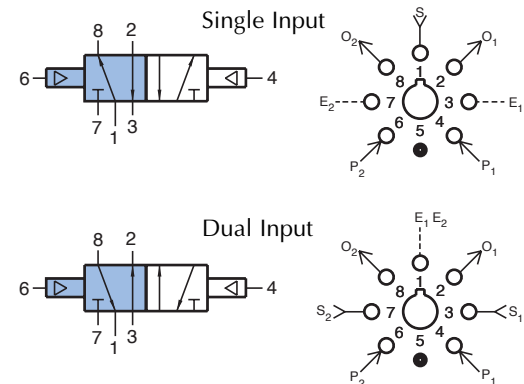

Description:

R-402 is a 4-way, double piloted, fully ported, 2-position valve. R-402 is a versatile component in basic logic circuits, and can perform all 2-, 3-, and 4-way functions. Operates double acting cylinders, and allows speed control by restricting exhaust ports.

R-405



L.P. Pilot Valve

Features:

- Pilot actuates valve with low pressure signal
- Micro gap construction - snap action and no blow by
- Balanced design allows speed control at exhausts

Performance:

Flow: 9 scfm @ 100 psig; 255 l/min @ 6.9 bars

Pilot Pressure Minimum: 15 psig; 1.0 bar

Temperature: 32° to 180° F

Working Pressure: 0 to 150 psig; 0 to 10.3 bars

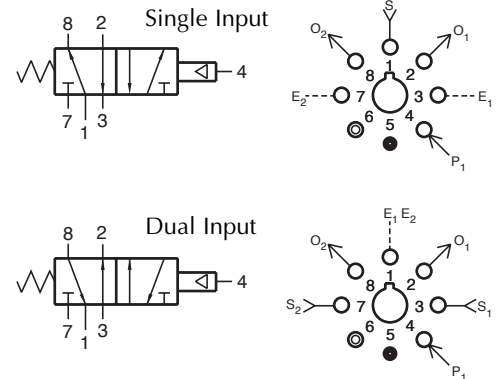

Description:

R-405 is a 4-way, spring-return, fully ported 5-port valve with a low pressure pilot. Pilot pressures as low as 15 psig will actuate the valve. It can perform all 2, 3, and 4-way functions. Operates double acting cylinders, allows speed control by restricting exhaust ports. It can be used with 1 input, 2 independent outputs and two independent exhausts, or with 2 independent inputs, 2 independent outputs and a common exhaust. The R-405 may be used in place of an [R-401](#) where lower pilot actuation pressure is desired.

R-410



4-Way Reset Valve

Features:

- Indicator shows valve in shaded position
- Micro gap construction - snap action and no blow by
- Balanced design allows speed control at exhausts
- Unique piloted spring reset

Performance:

Flow: 9 scfm @ 100 psig; 255 l/min @ 6.9 bars

Pilot Pressure Minimum (against spring): 40 psig; 2.8 bars

Pilot Pressure Minimum (spring retracted): 20 psig; 1.4 bars

Temperature: 32° to 180° F

Working Pressure: 0 to 150 psig; 0 to 10.3 bars

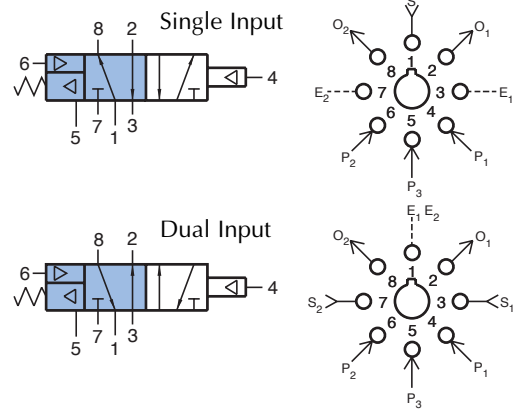

Description:

R-410 is a 4-way, fully ported valve with a special air retracted spring return that will return the valve to a definite position when there is no signal at ports 5 and 4. This "reset" feature may be used in circuits in the event of loss of air pressure or to change the operating characteristics of the valve in the circuit in response to an independent input at port 5. When port 5 is not piloted, the R-410 acts as a [R-401](#) 4-way spring return, fully ported valve. When port 5 is actuated, the R-410 acts as an R-402 4-way, two position valve. With no signal at port 5, a signal at port 6 acts as an auxiliary pilot type valve and will override a signal at port 4.

R-412

4-Way Reset Valve

Features:

- Indicator shows valve in shaded position
- Micro gap construction - snap action and no blow by
- Balanced design allows speed control at exhausts
- Reset feature allows for fail safe circuit design

Performance:

Flow: 9 scfm @ 100 psig; 254 l/min @ 6.9 bars

Pilot Pressure Minimum: 20 psig; 1.4 bars

Temperature: 32° to 180° F

Working Pressure: 0 to 150 psig; 0 to 10.3 bars

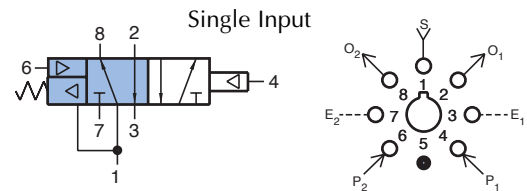

Description:

R-412 is a 5 ported 4-way double piloted, fully ported, 2-position valve with a special air-retracted spring that returns the valve to a definite position when the input air is off. This "memory" feature is ideal for circuitry where a definite starting position is required should the air supply fail and come on again unexpectedly. When there is pressure at port one, the spring pilot compresses the spring and holds it out of the way: valve functions normally as a double piloted 4-way valve identical to the [R-402](#).

R-421

3-Position, 4-Way Valve

Features:

- Micro gap construction - snap action and no blow by
- Three positions
- Balanced design allows speed control at exhausts

Performance:

Flow: 9 scfm @ 100 psig; 255 l/min @ 6.9 bars

Pilot Pressure Minimum: 40 psig; 2.8 bars

Temperature: 32° to 180° F

Working Pressure: 0 to 150 psig; 0 to 10.3 bars

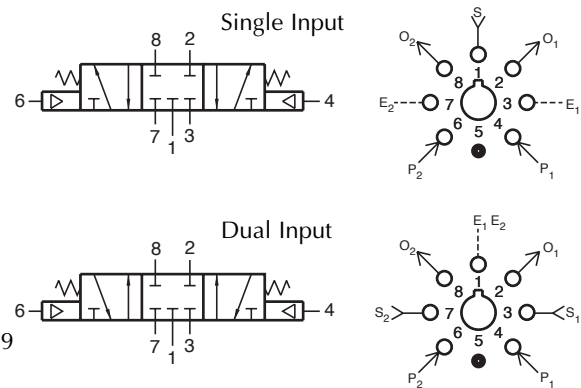

Description:

R-421 is a 4-way, 3-position, spring centered, fully ported valve. In the center position, all ports are blocked. It is ideal for approximate positioning and holding of pneumatic cylinders.

MODULAR 4-WAY TWIN PILOT VALVES



R-431



Twin Pilot 4-Way Valve

Features:

- Indicator shows valve in shaded position
- Micro gap construction - snap action and no blow by
- Dual pilots eliminate shuttle valve
- Balanced design allows speed control at exhausts

Performance:

Flow: 9 scfm @ 100 psig; 255 l/min @ 6.9 bars
Pilot Pressure Minimum: 40 psig; 2.8 bars
Temperature: 32° to 180° F
Working Pressure: 0 to 150 psig; 0 to 10.3 bars

Description:

R-431 is a 5 ported, 4-way valve, with spring return and dual pilots. When ports 5 and 2 are connected, a momentary pilot signal at port 4 will shift the valve to the "latched" position. It will remain in this position until the supply (port 1) is removed, or connection between ports 5 and 2 is interrupted.

Special Note: R-431 uses differential pilots and, as a result, the auxiliary pilot with the spring is not sufficiently large to cancel out the force of pilot 5. The auxiliary pilot will overcome pilot 4. The valve is actuated by pilot signals per the following chart:

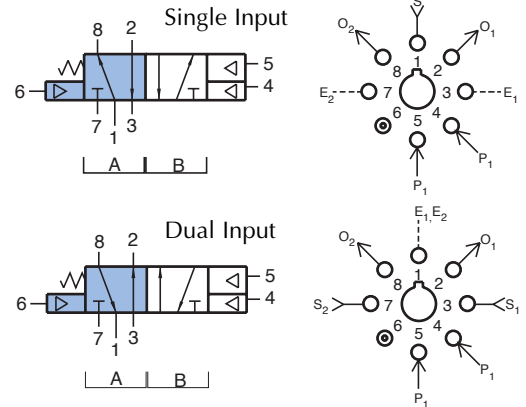

Pilot			Position
6	5	4	
off	off	off	A
off	off	on	B
off	on	on	B
off	on	off	B
on	off	off	A
on	off	on	A
on	on	off	B*

*Dependent on pressure relation of port 5 and 6

R-432



Twin Pilot 4-Way Valve

Features:

- Indicator shows valve in shaded position
- Micro gap construction - snap action and no blow by
- Dual pilots eliminate shuttle valve
- Balanced design allows speed control at exhausts

Performance:

Flow: 9 scfm @ 100 psig; 255 l/min @ 6.9 bars
Pilot Pressure Minimum: 20 psig; 1.4 bars
Temperature: 32° to 180° F
Working Pressure: 0 to 150 psig; 0 to 10.3 bars

Description:

R-432 is a 5 ported, 4-way, two position, double piloted valve.

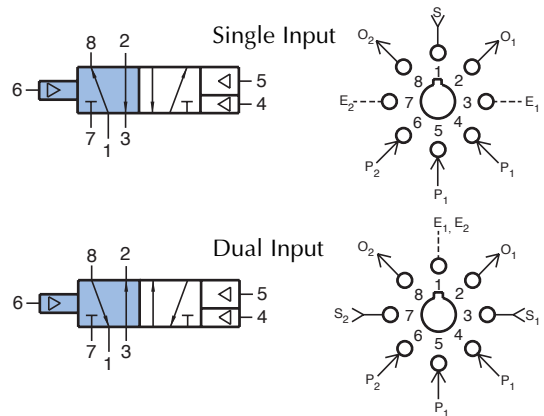



MODULAR 4-WAY TWIN PILOT VALVES

R-433

Twin Pilot 4-Way Valve



Features:

- Indicator shows valve in shaded position
- Micro gap construction - snap action and no blow by
- Dual pilots eliminate shuttle valve
- Balanced design allows speed control at exhausts

Performance:

Flow: 9 scfm @ 100 psig; 255 l/min @ 6.9 bars
Pilot Pressure Minimum: 40 psig; 2.8 bars
Temperature: 32° to 180° F
Working Pressure: 0 to 150 psig; 0 to 10.3 bars

Description:

R-433 is a 5 ported, 4-way valve, with spring return and dual pilots.

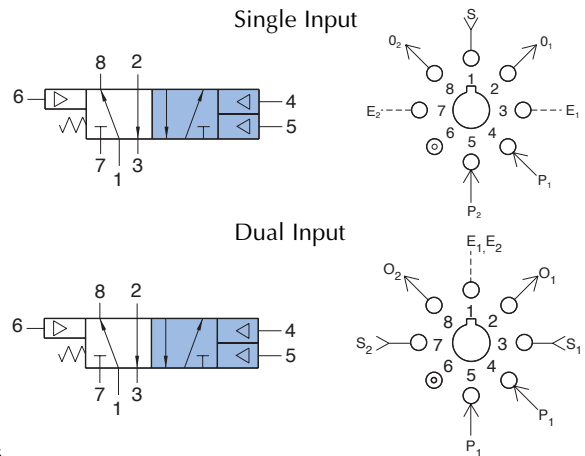

R-434

Twin Pilot 4-Way Valve



Features:

- Indicator shows valve in shaded position
- Micro gap construction - snap action and no blow by
- Dual pilots eliminate shuttle valve
- Balanced design allows speed control at exhausts

Performance:

Flow: 9 scfm @ 100 psig; 255 l/min @ 6.9 bars
Pilot Pressure Minimum: 20 psig; 1.4 bars
Temperature: 32° to 180° F
Working Pressure: 0 to 150 psig; 0 to 10.3 bars

Description:

R-434 is a 5 ported, 4-way, two position, double piloted valve.

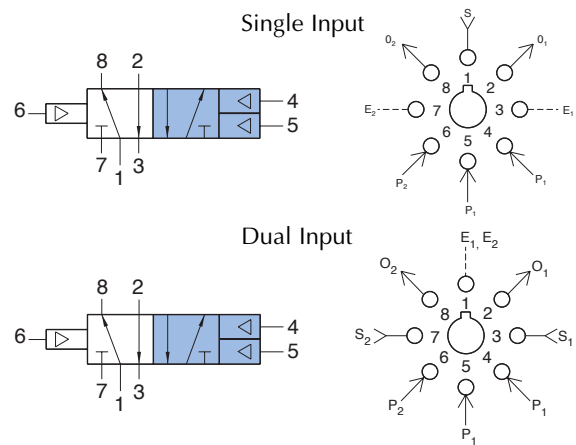

R-436

Dual Twin Pilot 4-Way Valve



Features:

- Micro gap construction - snap action and no blow by
- Dual pilots eliminate shuttle valve
- Balanced design allows speed control at exhausts

Performance:

Flow: 9 scfm @ 100 psig; 255 l/min @ 6.9 bars
Pilot Pressure Minimum: 20 psig; 1.4 bars
Temperature: 32° to 180° F
Working Pressure: 0 to 150 psig; 0 to 10.3 bars

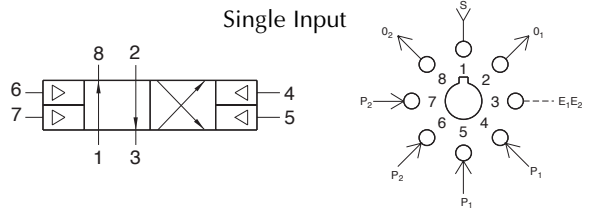

Description:

R-436 is a 4-way, two position valve with two pilots on each side. Actuating more than one pilot on the same side has no additional effect. Pilot signals must be absent from all pilots on one side before an opposite pilot will shift the valve. Port 3 is used as a common exhaust path.

Pneumatic Liquid Dispenser

Clippard Modular Valve Circuit with Adjustable Pressure and Auto Sequencing Control allows for no drip, metered dispensing.

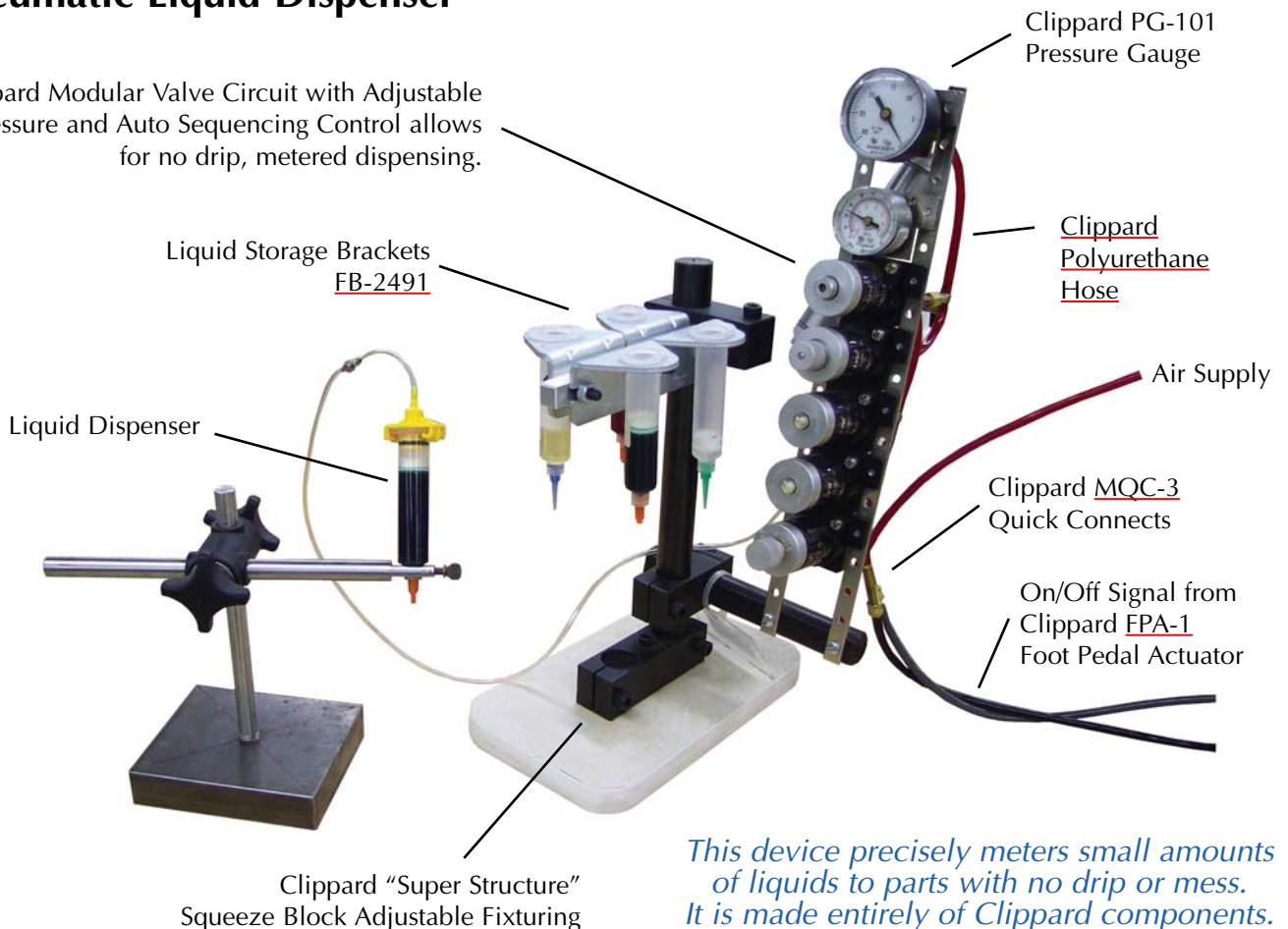

This device precisely meters small amounts of liquids to parts with no drip or mess. It is made entirely of Clippard components.



MODULAR 4-WAY BLEED PILOT VALVES

R-441



4-Way Valve

Features:

- Indicator shows valve in shaded position
- Micro gap construction - snap action and no blow by
- Balanced design allows speed control at exhausts

Performance:

Flow: 9 scfm @ 100 psig; 255 l/min @ 6.9 bars
Pilot Pressure Minimum: 40 psig; 2.8 bars
Temperature: 32° to 180° F
Working Pressure: 0 to 150 psig; 0 to 10.3 bars

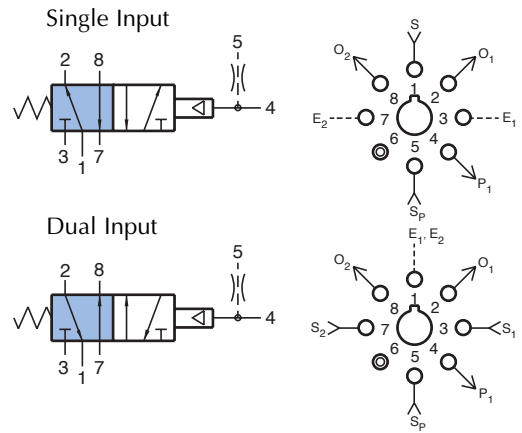

Description:

R-441 is a 4-way, spring return, bleed piloted valve for use with simple low force sensors. The vent supply pressure is independent of the inlet pressure to the valve. This pilot supply passes through a built-in restriction and shifts the valve compressing the spring. Venting (exhausting) the pressure in the pilot chamber (faster than the restricted supply can recover) shifts the valve.

R-442



4-Way Valve

Features:

- Indicator shows valve in shaded position
- Micro gap construction - snap action and no blow by
- Balanced design allows speed control at exhausts

Performance:

Flow: 9 scfm @ 100 psig; 255 l/min @ 6.9 bars
Pilot Pressure Minimum: 20 psig; 1.4 bars
Temperature: 32° to 180° F
Working Pressure: 0 to 150 psig; 0 to 10.3 bars

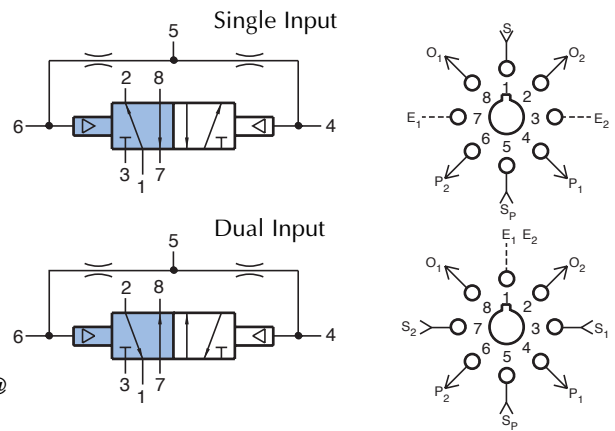

Description:

R-442 is a 4-way, double bleed pilot valve. The vent supply pressure is independent of the inlet pressure to the valve. Pilot supply passes through built-in restrictions and pressurizes both pilots. Venting (exhausting) the pressure in one pilot chamber (faster than the restricted supply can recover) causes the valve to be shifted by the opposite pilot.

R-443



4-Way Delay Valve

Features:

- Micro gap construction - snap action and no blow by
- Screwdriver slot needle adjustment deters tampering
- Balanced design allows speed control at exhausts

Performance:

Flow: 9 scfm @ 100 psig; 255 l/min @ 6.9 bars

Pilot Pressure Minimum: 40 psig; 2.8 bars

Temperature: 32° to 180° F

Working Pressure: 0 to 150 psig; 0 to 10.3 bars

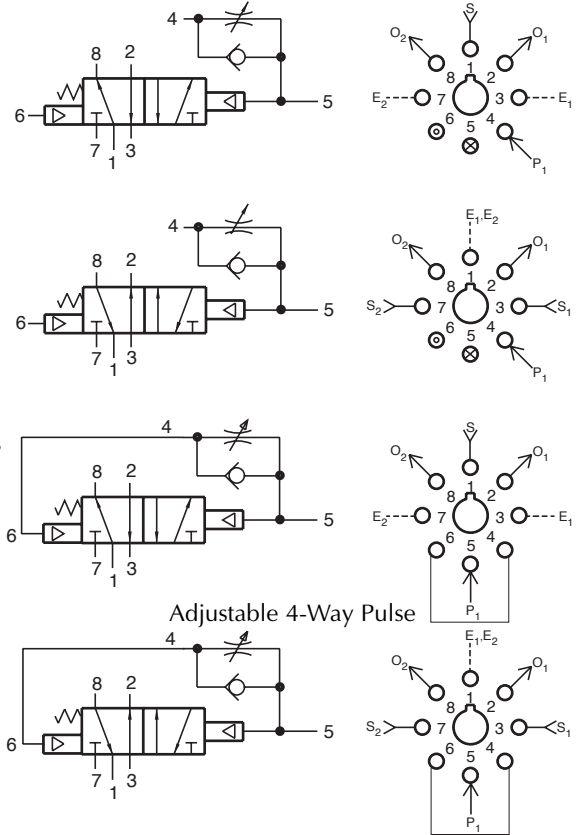

Description:

R-443 is a 4-way, spring return, fully ported 5-port valve with an adjustable flow control valve interconnected to the pilot. A pilot input signal in port 4 actuates the valve. When the pilot signal is exhausted it is delayed, out keeping the valve actuated until the pilot pressure has decayed. The R-443 can perform all 2, 3, and 4-way functions. The R-443 also features an auxiliary pilot on the spring side of the valve. Port 5 is an auxiliary for adding volume for longer time delays, if not used, port 5 should be plugged.

R-445



4-Way Delay Valve

Features:

- Micro gap construction - snap action and no blow by
- Screwdriver slot needle adjustment deters tampering
- Balanced design allows speed control at exhausts

Performance:

Flow: 9 scfm @ 100 psig; 255 l/min @ 6.9 bars

Pilot Pressure Minimum: 40 psig; 2.8 bars

Temperature: 32° to 180° F

Working Pressure: 0 to 150 psig; 0 to 10.3 bars

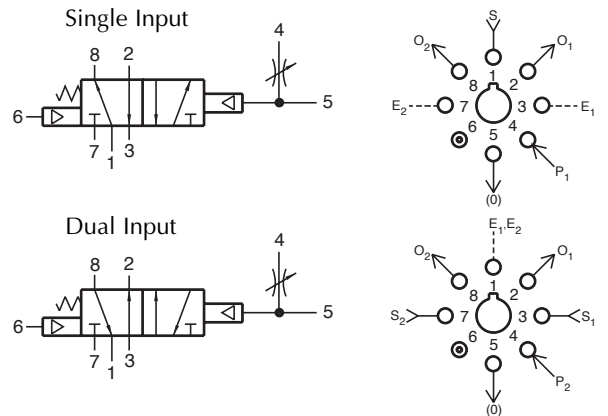

Description:

R-445 is a 4-way, spring return, fully ported, 5-port valve with an adjustable needle valve connected in parallel to the pilot. A pilot signal input in port 4 will be delayed in before actuating the valve. When the pilot signal is exhausted it is delayed out keeping the valve actuated until the pilot pressure has decayed. The R-445 can perform all 2-, 3-, and 4-way functions. The R-445 also features an auxiliary pilot by a constant supply to 4 and connecting port 5 to a bleed valve.

R-451



Binary Trigger Valve

Features:

- Micro gap construction - snap action and no blow by
- Dual pilots eliminate shuttle valve
- Balanced design allows speed control at exhausts

Performance:

Flow: 9 scfm @ 100 psig; 255 l/min @ 6.9 bars

Pilot Pressure Minimum: 40 psig; 2.8 bars

Temperature: 32° to 180° F

Working Pressure: 0 to 150 psig; 0 to 10.3 bars

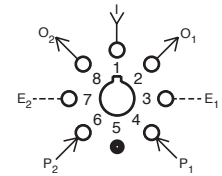
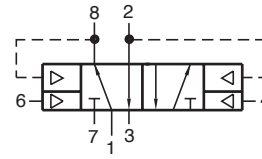

Description:

R-451 is a special purpose valve designed to work in conjunction with the [R-402/R412](#) valve to provide a single input flip-flop (binary sub-circuit).

R-453



4-Way Delay Valve

Features:

- Micro gap construction - snap action and no blow by
- Screwdriver slot needle adjustment deters tampering
- Balanced design allows speed control at exhausts

Performance:

Flow: 9 scfm @ 100 psig; 255 l/min @ 6.9 bars

Pilot Pressure Minimum: 40 psig; 2.8 bars

Temperature: 32° to 180° F

Working Pressure: 0 to 150 psig; 0 to 10.3 bars

Single Input

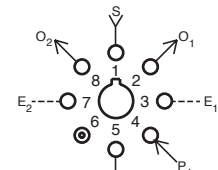
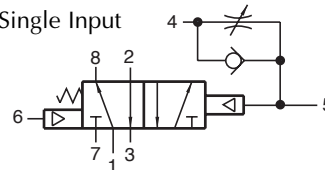

Dual Input

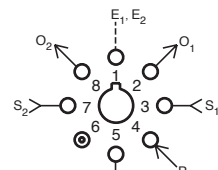
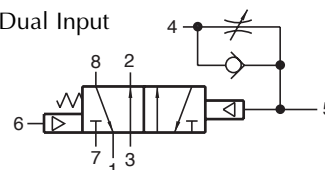

Description:

R-453 is a 4-way, spring return, fully ported 5 port valve with an adjustable flow control valve interconnected to the pilot. A pilot signal input in port 4 will be delayed in before actuating the valve. When the pilot signal is exhausted, the spring shifts the valve. The R-453 can perform all 2-, 3-, and 4-way functions. The R-453 also features an auxiliary pilot on the spring side of the valve.

R-454



4-Way Delay Valve

Features:

- Micro gap construction - snap action and no blow by
- Screwdriver slot needle adjustment deters tampering
- Balanced design allows speed control at exhausts

Performance:

Flow: 9 scfm @ 100 psig; 255 l/min @ 6.9 bars
Pilot Pressure Minimum: 40 psig; 2.8 bars
Temperature: 32° to 180° F
Working Pressure: 0 to 150 psig; 0 to 10.3 bars

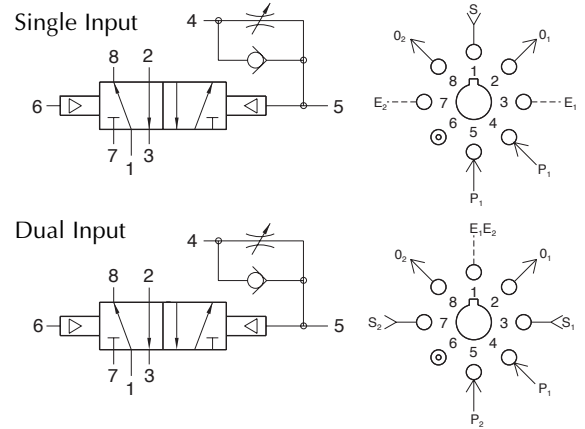

Description:

R-454 is a 4-way, double pilot, fully ported 5 port valve with an adjustable flow control valve interconnected to one pilot. A pilot signal input in port 4 will be delayed in before actuating the valve. The R-454 can perform all 2-, 3- and 4-way functions.

R-461



4-Way Valve, 6-Ported

Features:

- Indicator shows valve in shaded position
- Micro gap construction - snap action and no blow by
- Balanced design allows speed control at exhausts

Performance:

Flow: 9 scfm @ 100 psig; 255 l/min @ 6.9 bars
Pilot Pressure Minimum: 40 psig; 2.8 bars
Temperature: 32° to 180° F
Working Pressure: 0 to 150 psig; 0 to 10.3 bars

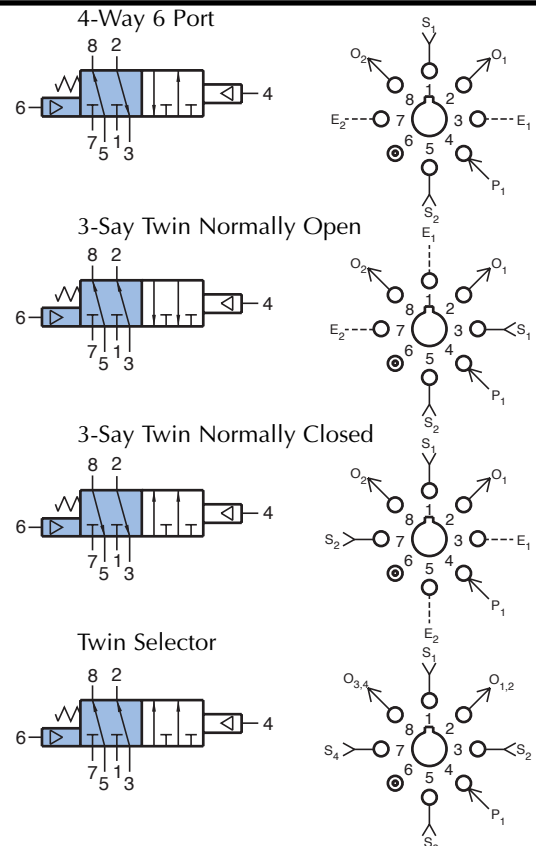

Description:

R-461 is a 6-ported, 4-way, spring return, fully ported, pilot operated valve. It is basically two fully ported 3-way valves with a common pilot. It can be used in a variety of applications including dual pressure operations with two independent inlets, outlets, and exhausts.



MODULAR 4-WAY VALVES

R-462

4-Way Valve, 6-Ported

Features:

- Indicator shows valve in shaded position
- Micro gap construction - snap action and no blow by
- Balanced design allows speed control at exhausts

Performance:

Flow: 9 scfm @ 100 psig; 255 l/min @ 6.9 bars
Pilot Pressure Minimum: 20 psig; 1.4 bars
Temperature: 32° to 180° F
Working Pressure: 0 to 150 psig; 0 to 10.3 bars

Description:

R-462 is a 6-ported, 4-way, double piloted, fully ported, two position valve. It is basically two fully ported 3-way valves with a common pilot. It can be used in a variety of applications including dual pressure operations with two independent inlets, outlets and exhausts.

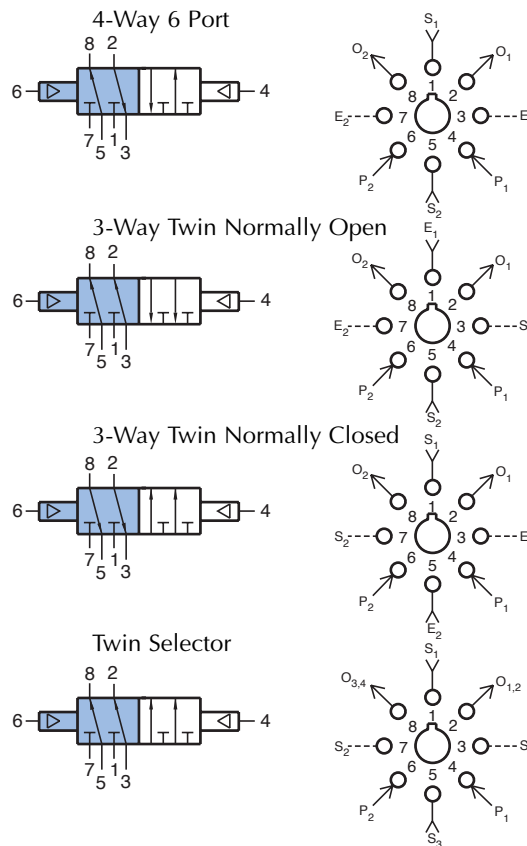

R-465

Low Pressure 4-Way Valve, 6-Ported

Features:

- Pilot actuates valve with low pressure signal
- Multiple porting speeds piping
- Micro gap construction - snap action and no blow by
- Balanced design allows speed control at exhausts

Performance:

Flow: 9 scfm @ 100 psig; 255 l/min @ 6.9 bars
Pilot Pressure Minimum: 15 psig; 1.0 bar
Temperature: 32° to 180° F
Working Pressure: 0 to 150 psig; 0 to 10.3 bars

Description:

R-465 is a 6-ported, 4-way, spring-return, fully ported valve with a low pressure pilot. Pilot pressures as low as 15 psig will actuate the valve. It is basically two fully ported 3-way valves with a common low pressure pilot. It can be used in a variety of applications including dual pressure operation, with two independent inlets, outlets and exhausts. The R-465 may be used in place of an R-461 where a lower pilot actuation pressure is desired.

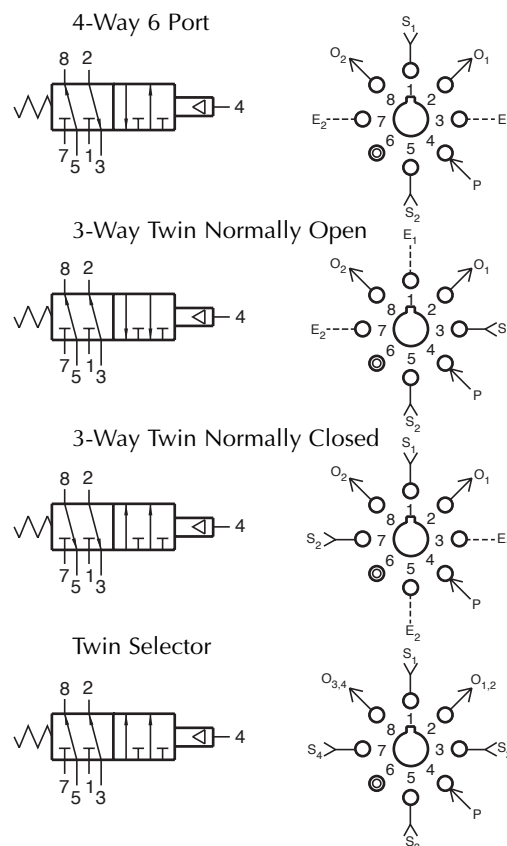

R-471



4-Way Amplified Pilot Valve

Features:

- Micro gap construction - snap action and no blow by
- Clippard 3200 bleed type amplifier section assures long life and repeatability
- Standard octoport plug-in design

Performance:

Flow: 9 scfm @ 100 psig; 255 l/min @ 6.9 bars

Pilot Pressure (psig) Minimum: 8" H₂O on 1" H₂O off

Pilot Supply Pressure: 45 to 100 psig; 3.1 to 6.9 bars

Temperature: 32° to 180° F

Working Pressure: 0 to 150 psig; 0 to 10.3 bars

Bleed Flow (amplifier orifice): 0.010" (0.25)

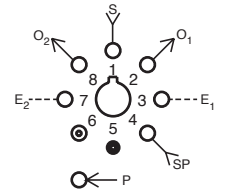
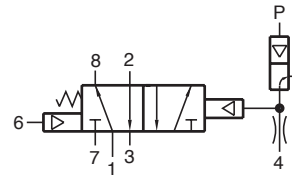

Description:

R-471 is a 4-way, fully ported, spring return, amplified pilot valve. The R-471 is a hybrid combination of the R-401 and model 3200 snap action valve.

R-472



4-Way Interface Valve

Features:

- Micro gap construction - snap action and no blow by
- Clippard 3200 bleed type amplifier section assures long life and repeatability
- Standard octoport plug-in design

Performance:

Flow: 9 scfm @ 100 psig; 255 l/min @ 6.9 bars

Pilot pressure (psig) Minimum: 8" H₂O on 1" H₂O off

Pilot Supply Pressure: 45 to 100 psig; 3.1 to 6.9 bars

Temperature: 32° to 180° F

Working Pressure: 0 to 150 psig; 0 to 10.3 bars

Bleed Flow (amplifier orifice): 0.010" (0.25)

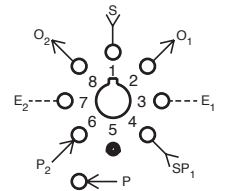
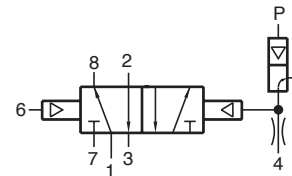

Description:

R-472 is a 4-way, fully ported, two position, amplified pilot valve. R-472 is a hybrid combination of the R-402 and model 3200 snap action valve.



MODULAR 4-WAY ELECTRONICALLY PILOTED VALVES

R-481-□



Electronic Valve

Features:

- Extremely low power consumption
- Micro gap construction - snap action and no blow by
- Standard octoport plug-in design
- Provides interface between electronics and pneumatics

Performance:

Working Range: 0 to 150 psig; 0 to 10.3 bars

Flow: 9 scfm @ 100 psig; 255 l/min @ 6.9 bars

Pilot Pressure (on port 4): 40 to 105 psig; 2.8 to 7.2 bars

Temperature: 32° to 180° F

Power Consumption: 0.65 watt at rated voltage

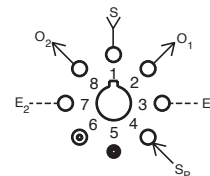
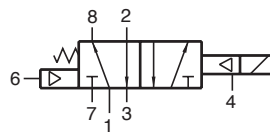

Voltage	R-481-6	6 VDC
	R-481-12	12 VDC
	R-481-24	24 VDC

Duty: Continuous duty at 150% of rated voltage (50% overload) permissible

Description:

R-481 is a fully ported (5-ported), 4-way valve. It is essentially a hybrid valve consisting of the R-401 valve and the Clippard model ET-3 electronic/pneumatic valve. The ET-3 responds to low current, low voltage signals and pneumatically actuates the R-401 4-way valve to which it is attached. A 40 psig pilot pressure must be present at port 4.

R-482-□



Electronic Valve

Features:

- Extremely low power consumption
- Micro gap construction - snap action and no blow by
- Standard octoport plug-in design
- Provides interface between electronics and pneumatics

Performance:

Working Range: 0 to 150 psig; 0 to 10.3 bars

Flow: 9 scfm @ 100 psig; 255 l/min @ 6.9 bars

Pilot Pressure: 20 to 105 psig; 1.4 to 7.2 bars

At Port 6 (min): 20

Temperature: 32° to 180° F

Power Consumption: 0.65 watt at rated voltage

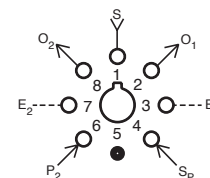
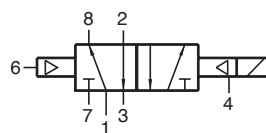

Voltage	R-482-6	6VDC
	R-482-12	12VDC
	R-482-24	24VDC

Duty: Continuous duty at 150% of rated voltage (50% overload) permissible

Description:

R-482 is a fully ported (5-ported), 4-way valve. It is essentially a hybrid valve consisting of the R-402 valve and the Clippard model ET-3 electronic/pneumatic valve. The ET-3 responds to low current, low voltage signals and pneumatically actuates the R-402 4-way valve to which it is attached. A 20 psig pilot pressure must be present at port 4.

R-501 R-502



Flow Control Valve

Features:

- Multiple porting speeds piping
- Knurled knob for fast, accurate adjustments - no tools needed
- Fine adjustment for pneumatic timing

Performance:

Flow: 0 to 1 scfm @ 100 psig; 0 to 28.3 l/min

Temperature: 32° to 180° F

Working Pressure: 0 to 150 psig; 0 to 10.3 bars

R-501 Delay In Flow Control

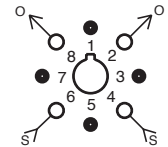
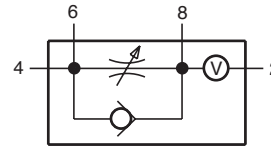

R-502 Delay Out Flow Control

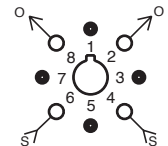
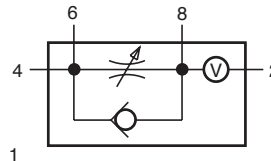

Description:

R-501 is an adjustable flow control designed to meter "IN" to an integral volume chamber to delay pressure build-up in one direction. Dual ports are provided to add extra volume or for multiple input-output connections.

R-502 is an adjustable flow control designed to meter "OUT" from an integral volume chamber to delay pressure decay in one direction.

R-602 R-603



Dual Shuttle Valves

Features:

R-602

- Bubble tight operation
- Two independent units in one module
- Saves space

R-603

- Complete three input subcircuit in one module
- Auxiliary outputs save fittings and time

Performance:

Flow: 10 scfm @ 100 psig; 283 l/min @ 6.9 bars

Temperature: 32° to 180° F

Working Pressure: 5 to 150 psig; 0.3 to 10.3 bars

R-602 Dual Shuttle Valve

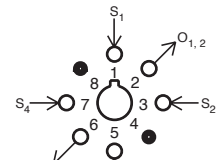
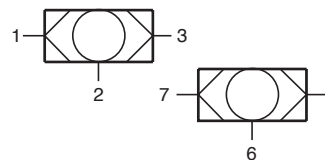

R-603 3-Input "OR"

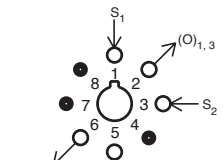
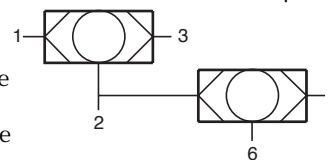

Description:

R-602 is a dual element combination consisting of two completely independent shuttle valves in a single body. R-603 is a dual element combination consisting of two shuttle valves which are interconnected into a subcircuit. It provides a 3-input "or" with port 2 available as an auxiliary. If not used, port 2 should be plugged.



MODULAR REGULATOR & PULSE VALVES

R-701

Pressure Regulator



Features:

- Multiple porting speeds piping
- Knurled knob for fast, accurate adjustments - no tools needed
- Self-relieving

Performance:

Flow: 12 scfm @ 100 psig; 340 l/min @ 6.9 bars
Temperature: 32° to 180° F
Working Pressure: 0 to 150 psig; 0 to 10.3 bars

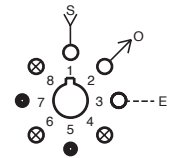
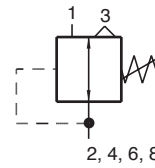

Description:

R-701 is a self-relieving, adjustable pressure regulator with multiple output ports. Pressure can be piped directly from ports 2, 4, 6 and 8. Eliminates need for additional fittings. Unused output ports should be plugged.

R-711

Pulse Valve



Features:

- Multiple porting speeds piping
- Micro Gap Construction - snap action and no blow by
- Complete function in one module

Performance:

Flow: 10 scfm @ 100 psig; 283 l/min @ 6.9 bars
Pilot Pressure Minimum: 40 psig; 2.8 bars
Temperature: 32° to 180° F
Working Pressure: 40 to 150 psig; 2.8 to 10.3 bars

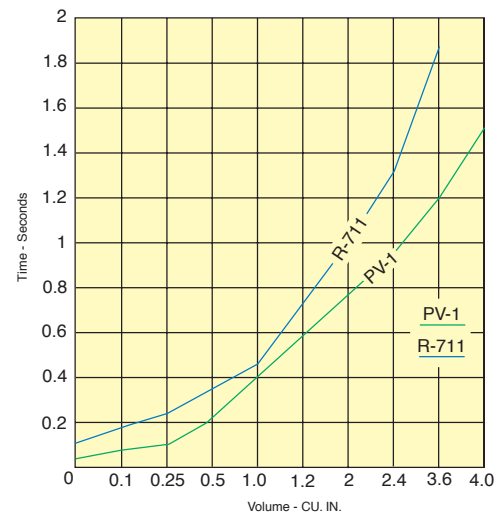
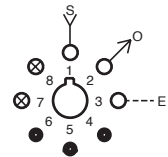
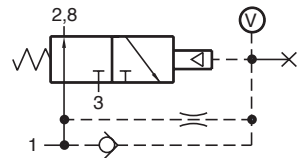

Time in Seconds			Time in Seconds		
Volume	PV-1	R-711	Volume	PV-1	R-711
0	0.042	0.117	1.2	0.580	0.700
0.1	0.074	0.180	2.0	0.760	1.000
0.25	0.124	0.245	2.4	0.950	1.300
0.5	0.210	0.350	3.6	1.200	1.900
1.0	0.390	0.450	4.0	1.500	N.R.

Description:

R-711 is a 3-way, normally-OPEN, self-piloted valve that closes shortly after being pressurized and remains closed until signal pressure is exhausted. It converts a continuous input signal into a single pulse of approximately 50 milliseconds. Port 7 is provided for additional volume for extending pulse duration and should be plugged if not used.

R-731



Modular Vacuum Generator

Turn pressure to vacuum generator on/off

Features:

- Indicator shows valve in shaded position
- Micro gap construction - snap action and no blow by

Performance:

3-Way Valve

- Flow:** 9 scfm @ 100 psig; 255 l/min @ 6.9 bars
- Pilot Pressure Minimum:** 40 psig; 2.8 bars
- Temperature:** 32° to 180° F
- Working Pressure:** 0 to 150 psig; 0 to 10.3 bars

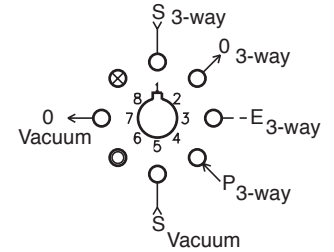
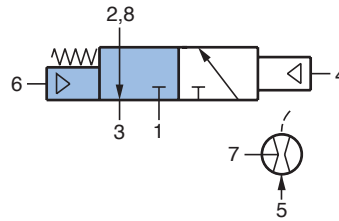

Vacuum Generator

- Vacuum (in. Hg @ 60 psig):** 25
- Vacuum Flow:** 0.6 scfm @ 60 psig; 17 l/min @ 4.1 bars
- Air Consumption:** 1.7 scfm @ 60 psig; 48 l/min @ 4.1 bars
- Temperature:** 32° to 180° F

Description:

The R-731 is a combination venturi vacuum generator and an independent pilot actuated, spring return, fully ported 3-way valve. Applying pressure at port 5 creates a vacuum at port 7. The 3-way valve can be used to turn the vacuum generator on or off or it can be used to switch the vacuum on or off. 40 psig is required to pilot the 3-way valve.

For mounting and muffler information see [page 273](#).

R-732



Modular Vacuum Generator

Select Pressure or Vacuum Output

Features:

- Indicator shows valve in shaded position
- Micro gap construction - snap action and no blow by

Performance:

3-Way Valve

- Flow:** 9 scfm @ 100 psig; 255 l/min @ 6.9 bars
- Pilot Pressure Minimum:** 20 psig; 1.4 bars
- Temperature:** 32° to 180° F
- Working Pressure:** 0 to 150 psig; 0 to 10.3 bars

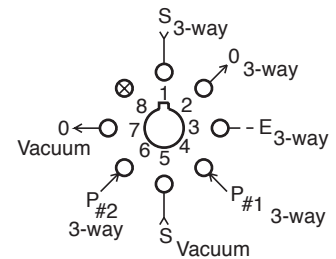
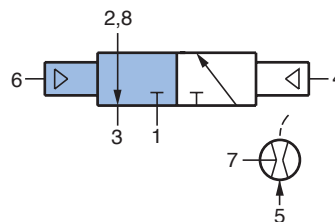

Vacuum Generator

- Vacuum (in. Hg @ 60 psig):** 25
- Vacuum Flow:** 0.6 scfm @ 60 psig; 17 l/min @ 4.1 bars
- Air Consumption:** 17 scfm @ 60 psig; 481 l/min @ 4.1 bars
- Temperature:** 32° to 180° F

Description:

The R-732 is a combination venturi vacuum generator and an independent double pilot actuated, fully ported 3-way valve. Applying pressure at port 5 creates a vacuum at port 7. The 3-way valve can be used to turn the vacuum generator on or off or it can be used to switch the vacuum on or off. 20 psig is required to pilot the 3-way valve.

For mounting and muffler information see [page 273](#).



VACUUM GENERATOR

R-781-□



Modular Vacuum Generator

Turn Vacuum on/off

Features:

- Micro gap construction - snap action and no blow by

Performance:

3-Way Valve

Flow: 9 scfm @ 100 psig; 255 l/min @ 6.9 bars

Pilot Pressure Minimum: 20 psig; 1.4 bars

Temperature: 32° to 180° F

Working Pressure: 0 to 150 psig; 0 to 10.3 bars

Vacuum Generator

Vacuum (in. Hg @ 60 psig): 25

Vacuum Flow (scfm @ 60 psig): 0.6

Air Consumption (scfm @ 60 psig): 1.7

Temperature: 32° to 180° F

Available Voltage: 6, 12, 24 VDC

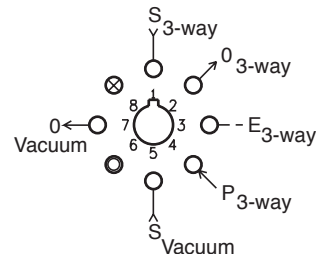
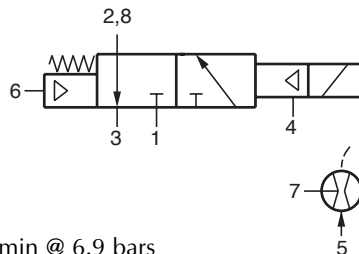

Voltage	<u>R-781-6</u>	6 VDC
	<u>R-781-12</u>	12 VDC
	<u>R-781-24</u>	24 VDC

Power Consumption: 0.65 W @ rated voltage

Duty: Continuous duty to 150% of rated voltage

Description:

R-781 is a combination venturi vacuum generator and an independent pilot actuated electronically controlled, spring return, fully ported 3-way valve. Applying pressure at port 5 creates a vacuum at port 7. The 3-way valve can be used to turn the vacuum generator on or off or it can be used to switch the vacuum on or off. To shift the 3-way valve 40 psig is required at port 4 along with the appropriate DC voltage being applied to the solenoid.

R-782-□



Modular Vacuum Generator

Features:

- Micro gap construction - snap action and no blow by

Performance:

3-Way Valve

Flow: 9 scfm @ 100 psig; 255 l/min @ 6.9 bars

Pilot Pressure Minimum: 20 psig; 1.4 bars

Temperature: 32° to 180° F

Working Pressure: 0 to 150 psig; 0 to 10.3 bars

Vacuum Generator

Vacuum (in. Hg @ 60 psig): 25

Vacuum Flow: 0.6 scfm @ 60 psig

Air Consumption: 1.7 scfm @ 60 psig

Temperature: 32° to 180° F

Available Voltage: 6, 12, 24 VDC

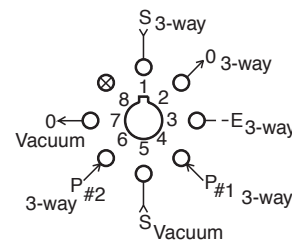
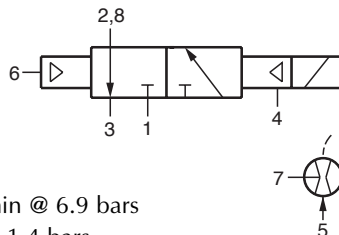

Voltage	<u>R-782-6</u>	6 VDC
	<u>R-782-12</u>	12 VDC
	<u>R-782-24</u>	24 VDC

Power Consumption: 0.65 W @ rated voltage

Duty: Continuous duty to 150% of rated voltage

Description:

The R-782 is a combination venturi vacuum generator and an independent pilot actuated electronically controlled, air pilot return, fully ported 3-way valve. Applying pressure at port 5 creates a vacuum at port 7. The 3-way valve can be used to turn the vacuum generator on or off or it can be used to switch the vacuum on or off. To shift the 3-way valve 20 psig is required at port 4 along with the appropriate DC voltage being applied to the solenoid. To return the valve a pilot pressure of 20 psig is required at port 6.

MODULAR VACUUM GENERATOR



The Modular Vacuum Generator is a combination venturi vacuum generator and 3-way valve, contained in a modular body for simplicity and ease of installation. This combination allows the user to control the pressure to the vacuum generator, vacuum from the generator, and other circuit functions as required.

With 60 psig air to the modular generator, a vacuum of 25 in. Hg and 0.6 scfm is generated from the outlet. This vacuum may be used for pick, place, and hold applications, or liquid drawback circuits and is an energy efficient alternative to both electric and multi-stage air powered pumps.

The venturi vacuum generator provides a low cost vacuum source with no required maintenance. It contains a large flow path in a design that is self-cleaning, eliminating the need for a filtered air supply.

The 3-way valve is a proven Clippard modular valve design utilizing micro gap construction for a very short stroke of the balanced spool.

The Clippard modular vacuum generator uses a Delrin® body with a central valve cavity surrounded by (8) independent air passages that terminate at the base of the body in a circular, octoport pattern. The body mates with a manifold subplate (sold separately) that mounts the complete module and provides #10-32 tapped holes for standard hose fittings.

A single octoport gasket (included with the module), held in place by two mounting screws, insures a positive seal.

Performance: Clippard modular vacuum generators provide high vacuum flow with high vacuum levels and are field adjustable. The adjustment screw at the base of the modular allows setting to the optimum performance needed to perform the task.

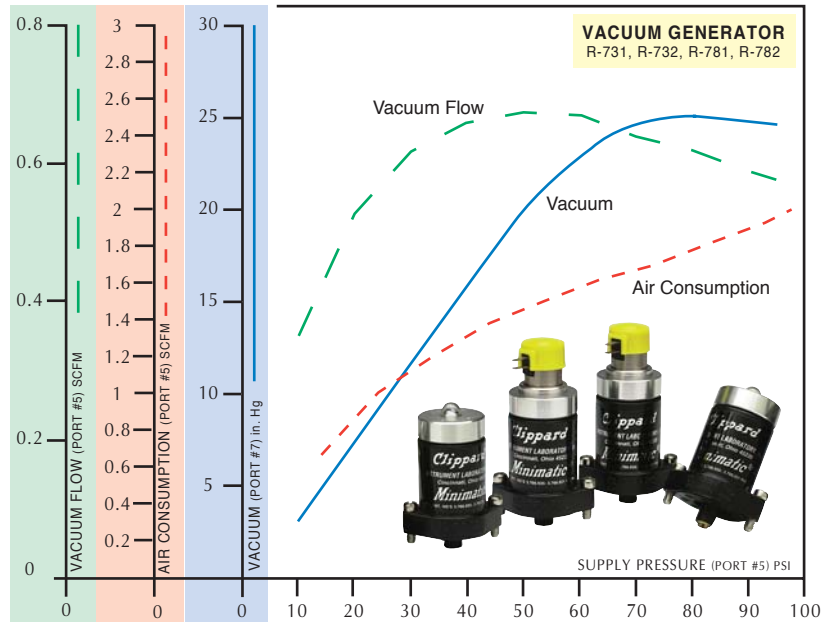

Muffler 3849-1



The 3849-1 muffler is constructed of durable polyethylene with a 1/8" NPT male thread which installs in the extension of either the [R-101-10](#) or [R-111-10](#) subplate.

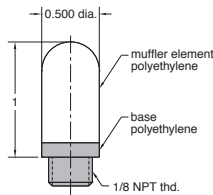

Gauge VG-30



Inlet Vacuum: scale reading from 0 to -30 in. Hg. & 0 to -1 bar

Construction: black case, plastic face, dial shows two ranges; in. Hg in black, bars in red; built-in pressure snubber

Ports: connection located at rear is threaded both O.D. - male thread 1/8" NPT I.D. - tapped for #10-32 fitting

Mounting: Stud mount using 1/8" NPT center stud or panel mount using the zinc plated steel bracket supplied.

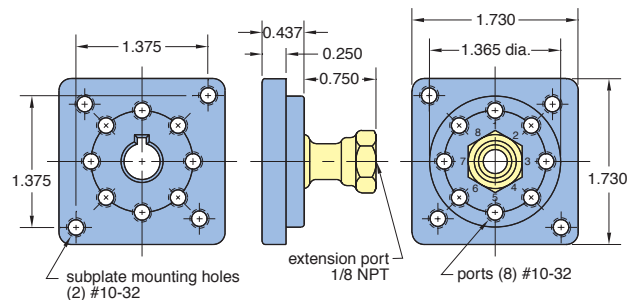
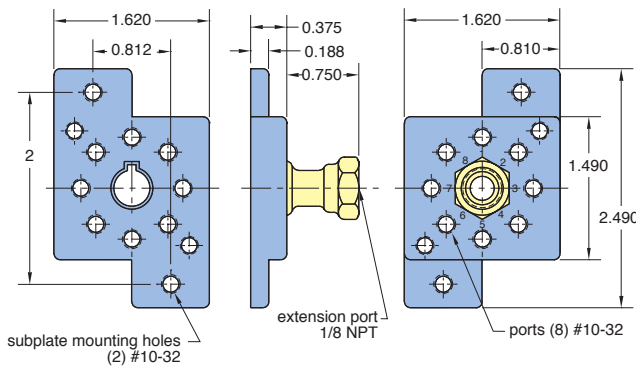

Subplate Dimensions

The [R-101-10](#) subplate mounts to mounting strips with #10-32 screws and lockwashers provided. Ports on module base are numbered in the same pattern as on the subplate, making piping easy to identify. Module stem is keyed to fit center hole in subplate; assures fast insertion and proper positioning.

[R-111-10](#) subplate mounts in 1 3/8" hole in electrical box, control panel. Mounting screws and gasket provided seal subplate to mounting plate.





MODULAR VOLUME CHAMBER, FILTER & SEQUENCE VALVE

R-801



Filter

Features:

- Multiple porting speeds piping
- Clean out port for easy maintenance
- Protects system - assures proper functioning
- Replaceable filter element (Part no. R-801-14)

Performance:

Flow: 12 scfm @ 100 psig; 339 l/min @ 6.9 bars

Temperature: 32° to 180° F

Working Pressure: 0 to 150 psig; 0 to 10.3 bars

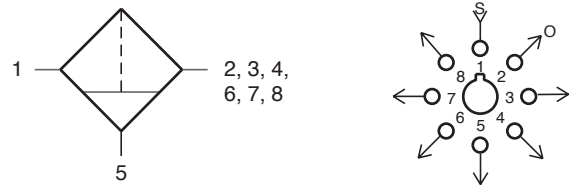

Description:

R-801 is a 25 micron filter with multiple outlets at ports 2, 3, 4, 6, 7 and 8 to minimize need for fittings. Port 5 is a drain and should be plugged; however, when the valve is mounted vertically port 5 can be tubed to a drain. Unused ports should be plugged.

R-811



Connector

Connects to subplate [R-101/R101-M5](#), [R-111/R-111-M5](#) and manifolds

Description:

R-811 is an octoport connector that provides rapid and accurate connection of up to eight hoses. Truly a convenience connection; saves time; eliminates mistakes.

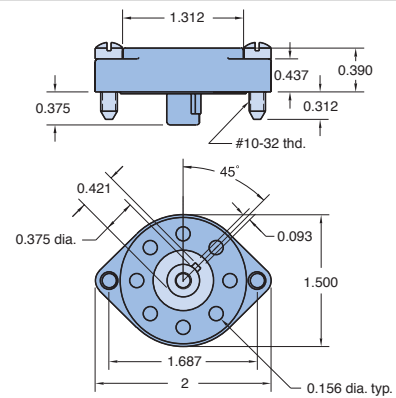

R-821



Volume Chamber

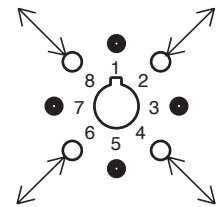
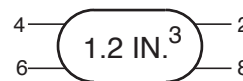

Description:

Volume chamber provided in standard, plug-in Clippard Minimatic® module body, using standardized octoport. May be used for providing time delay in pneumatic circuits. This model has 1.2 cubic inch volume chamber.

R-901



Sequence Valve

Features:

- Indicator shows valve position
- Micro gap construction - snap action and no blow by
- Balanced design allows speed control at exhausts

Performance:

Flow: 9 scfm @ 100 psig; 255 l/min @ 6.9 bars

Pilot Pressure Minimum: 40 psig; 2.8 bars

Temperature: 32° to 180° F

Working Pressure: 0 to 150 psig; 0 to 10.3 bars

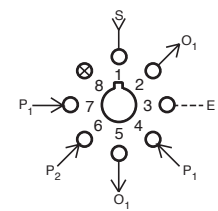
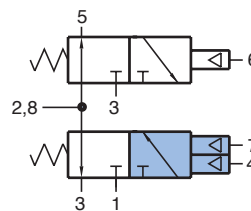

Description:

R-901 is a dual element combination consisting of a 3-way normally-closed, spring return air piloted valve and a 3-way normally-open, spring return, air piloted valve. One of the outputs of the N.C. valve is the input to the N.O. valve. A valve position indicator is provided for the N.C. valve. The R-901 is intended for use in sequential stepping control circuits.

R-932



Sequence Valve

Features:

- Indicator shows valve in shaded position
- Micro gap construction - snap action and no blow by

Performance:

Flow: 9 scfm @ 100 psig; 255 l/min @ 6.9 bars
Pilot Pressure Minimum: 20 psig; 1.4 bars
Temperature: 32° to 180° F
Working Pressure: 0 to 150 psig; 0 to 10.3 bars

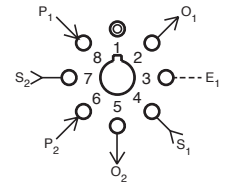
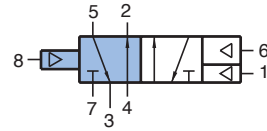

Uses:

The R-932 Sequence Control Module is a compact, efficient component for creating a sequential system for control of a multi-step operation. It has many uses throughout industry.

Description:

R-932 is a 4-way, 5 ported, double piloted, two position valve designed for sequence control application. Availability of two supply and two output ports enables the module to perform the sequential function. One output controls the operation assigned to that step in the cycle. The other output maintains the next step in a hold mode until ready for release. Likewise, the R-932 uses differential pilots. This enables the signal at port 6 to cancel out the force of the opposite pilot at port 8. Shifting of the valve is not possible until the signal at port 6 is removed. When a step is completed, a limit feedback signal actuates the next step. At the end of the sequence the last step resets all the sequence valves, resetting the operation for the next cycle. For each step in the cycle, a separated R-932 module must be used.

R-934



Sequence Valve

Features:

- Indicator shows valve in shaded position
- Micro gap construction - snap action and no blow by

Performance:

Flow: 9 scfm @ 100 psig; 255 l/min @ 6.9 bars
Pilot Pressure Minimum: 20 psig; 1.4 bars
Temperature: 32° to 180° F
Working Pressure: 0 to 150 psig; 0 to 10.3 bars

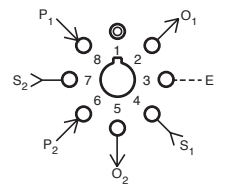
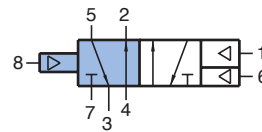

Description:

The R-934 sequence valve is the same as the R-932 sequence valve with the exception of ports 1 and 6. The R-934 port 6 pilot is the same size as the port 8 pilot. This provides a built in safety that if a limit valve is held actuated, the reset signal at port 6 will not reset the sequence, therefore stopping the system with the indicator being in the down position for trouble shooting. The R-934 sequence valve can only be used on the steps that do not have the input signal held normally open.



MODULAR ELECTRONIC SEQUENCING VALVES

R-982-□

Electronic Piloted Sequence Valve

Features:

- Extremely low power consumption
- Patented micro gap valving for quick action, no blow by
- Standard octoport plug-in design
- Provides interface between electronics and pneumatics

Performance:

Working Range: 20 -105 psig;
Flow: 9 scfm @ 100 psig; 255 l/min @ 6.9 bars
Pilot Pressure Minimum: 20 psig; 1.4 bars
Temperature: 32° to 180° F
Power Consumption: 0.65

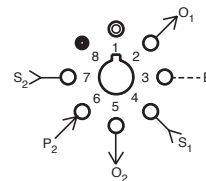
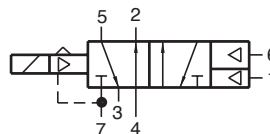

Voltage.....	R-982-6	6 VDC
	R-982-12	12 VDC
	R-982-24	24 VDC

Duty: Continuous duty at 150% of rated voltage

Description:

R-982 electronic sequence valve is essentially a hybrid valve consisting of the R-932 valve and the Clippard model ET-3 electronic/pneumatic valve. The ET-3 responds to low current, low voltage signals and pneumatically actuates the R-932 sequence valve to which it is attached.

R-984-□

Electronic Piloted Sequence Valve

Features:

- Extremely low power consumption
- Micro gap construction - snap action and no blow by
- Standard octoport plug-in design
- Provides interface between electronics and pneumatics

Performance:

Working Range: 20-105 psig; 1.4-7.2 bars
Flow: 9 scfm @ 100 psig; 255 l/min @ 6.9 bars
Pilot Pressure Minimum: 20 psig; 1.4 bars
Temperature: 32° to 180° F
Power Consumption: 0.65

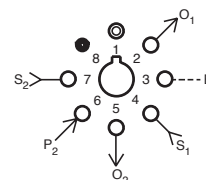
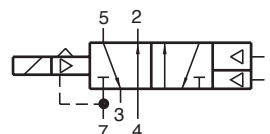

Voltage.....	R-984-6	6 VDC
	R-984-12	12 VDC
	R-984-24	24 VDC

Duty: Continuous duty at 150% of rated voltage

Description:

The R-984 electronic sequence valve is essentially a hybrid valve consisting of the R-934 valve and the Clippard model ET-3 electronic/pneumatic valve. The ET-3 responds to low current, low voltage signals and pneumatically actuates the R-934 sequence valve to which it is attached.

APPLICATION

ap-ply-ca-tion \ap-lə-ˈkâ-shən\ n 1 : the act of applying 2 : assiduous attention 3 : REQUEST; also : a form used in making a request 4 : something placed or spread on a surface 5 : capacity for use

The following circuits show a few of the many useful ways to use Clippard Minimatic® modular components in practical pneumatic circuitry. The drawings presented here are combinations of ANSI and pictorial symbols and Octoport piping diagrams. For more information and application assistance contact your nearest Clippard distributor.

Initial Approach to Designing a Pneumatic Control

1. Have a clear verbal understanding of the sequence of operations desired.
2. Put down on paper:
 - A. Manual controls necessary or required and what their function is to be.
 - B. Other available input signals from:
 1. Limit valves
 2. Sensors
 3. Other controls or control media
 - C. All output devices (cylinders, piloted valves, electrical motors, etc.) that are to be controlled.
3. Determine all mechanical interlocks that exist.
4. Determine all the safety interlocks that must exist.
5. Work out the logic portion of the control utilizing the inputs and outputs at hand. Employ the functional circuit concept. Remember even the most complicated control circuits are composites of smaller functional circuits.
6. Check the final circuit for proper actuation during:
 - A. Start up
 - B. Shut down
 - C. Loss of air
 - D. Panic stops in the middle of cycle
 - E. Restarts in the middle of the cycle
 - F. Control during other events that are likely to occur

Cycling Without Limit Valves

This circuit enables a double acting cylinder to reciprocate without the use of limit valves and to control its speed in each direction. As C-1 retracts, it creates a back-pressure behind the piston which is further increased by restricting the exhaust air at port 3, V-2, to slow the return of the cylinder rod. This back pressure holds the pilot closed on V-3. When C-1 has fully returned, the back pressure diminishes. When there is insufficient pressure to hold the pilot down on V-3, the spring shifts the valve, which sends pressure to the right hand pilot, port 4, of V-2. This causes V-2 to shift, which starts C-1 to extend and pilots V-3 exhausting the pressure on the right hand pilot of V-2.

As C-1 extends, an identical sequence occurs between V-1 and V-2, causing the 4-way valve to shift when C-1 has fully extended.

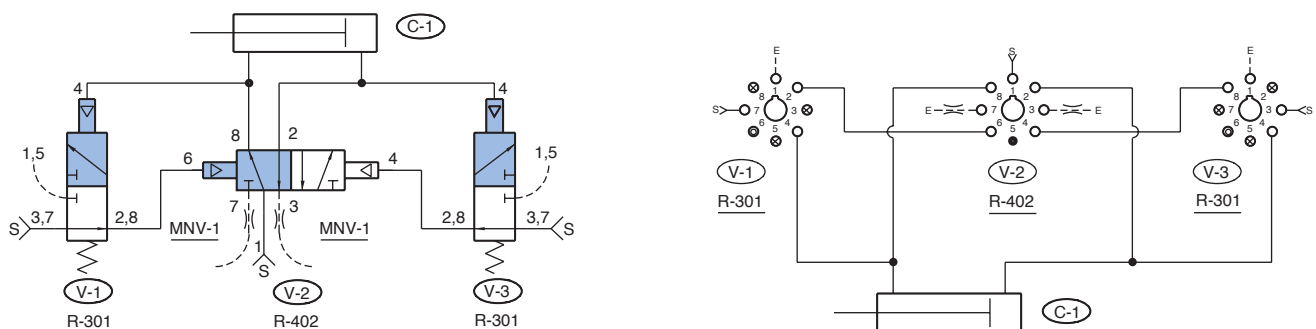

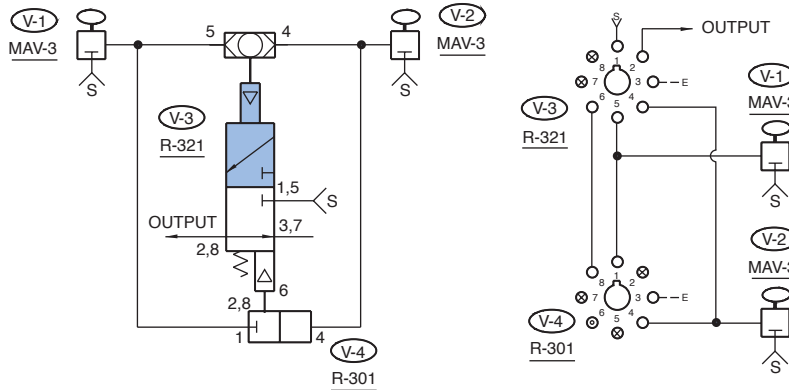

Exclusive "OR" Circuit

The exclusive "OR" circuit operates as follows: When V-1 is depressed, the signal goes to both V-3 and V-4. The signal at V-4 is blocked. The signal at V-3 actuates the valve and provides an output signal. If V-2 is actuated independently, the same sequence occurs.

If both V-1 and V-2 are actuated, the output at V-4 energizes the bottom pilot which, together with the spring, overrides the opposite pilot of V-3, nullifying both signals, V-3 thus remains off.

Circuit Function

INPUTS	V-1	off	off	on	on
	V-2	off	on	off	on
OUTPUT	V-3	off	on	on	off

Motion Sensing Circuit

V-1 is actuated by rotary or linear cam. Pressure from V-1 goes to a pulse valve (V-2) where it is converted to a uniform pulse each time V-1 is actuated. Each pulse goes through the check valve of V-3 and holds the pilot down on the valve. C-1 is retracted. The pressure holding the pilot of V-3 is constantly trying to exhaust through the adjustable needle valve V-3 and out to atmosphere through the exhaust port of the pulse valve V-2.

When motion stops (or falls below a pre-determined C.P.M.) the pressure on the pilot of V-3 exhausts and the spring shifts the valve, which causes C-1 to extend. The R-341 is shown as normally closed. It can also be used as normally open, a selector, or a diverter.

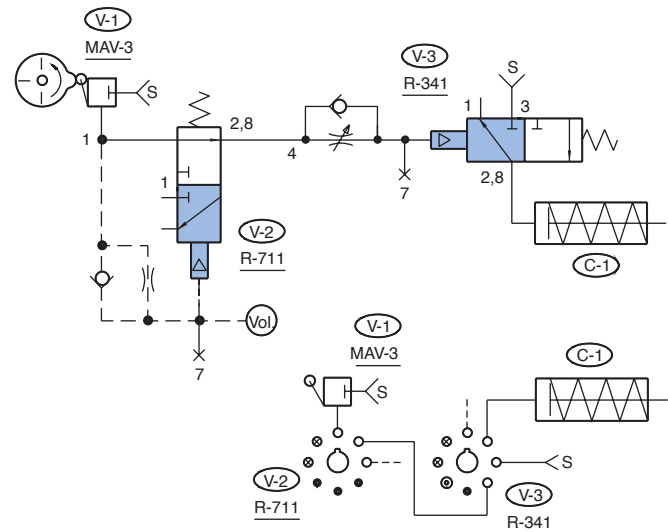

Signal Release Pulse Circuit

This circuit gives a single pulse output of adjustable duration when its input signal is released (exhausted). Upon actuation of the input 3-way valve, V-1, air is supplied to both valve pilots simultaneously so the valve, V-2, remains in the closed position. Upon release of the input signal the pilot on the spring side of the valve is exhausted immediately. This allows the "trapped" air in the volume tank to actuate the valve causing the output to come on. The valve remains actuated until the trapped air bleeds off through the adjustable needle valve.

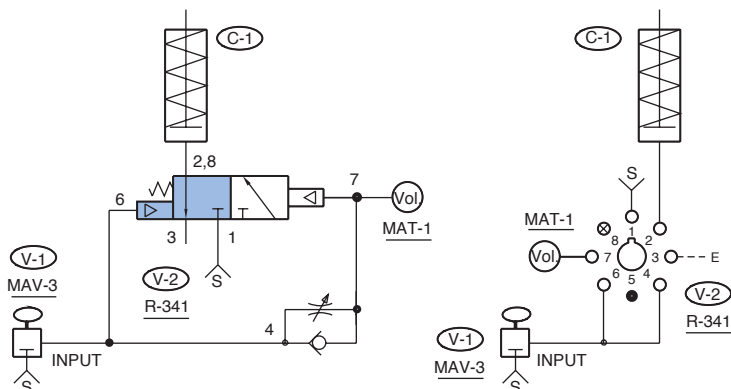

Use of Shuttle Valves

The **R-603** is a three input shuttle valve sometimes called a three input "OR". Actuation of V-1 or V-2 or V-3 will give an output at port 6, of V-4, and extend C-1.

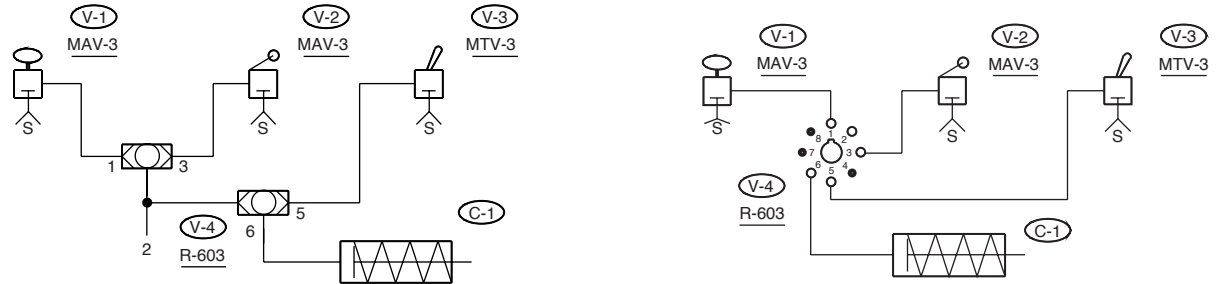

Adjustable 4-Way Pulse

When V-1 is actuated a signal pilots port 4, V-3, extending C-1. The signal is also going to the auxiliary pilot but is delayed by the flow control V-2. When pressure builds up on the pilot, port 6, V-3, it, together with the spring, overcomes the opposite pilot and shifts the valve. C-1 then retracts. V-3 will not cycle again until V-1 is released.

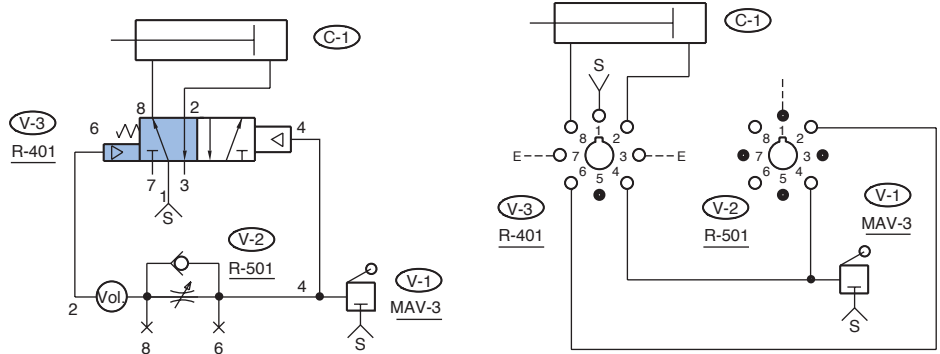

Two Hand No Tie Down

This circuit provides an output signal to power or pilot a piece of machinery when two push buttons are manually pressed simultaneously. Neither button can be tied down. The output will cease if either button is released. See **CM-023** in the **Pneumatic Circuit Board** section for more details.

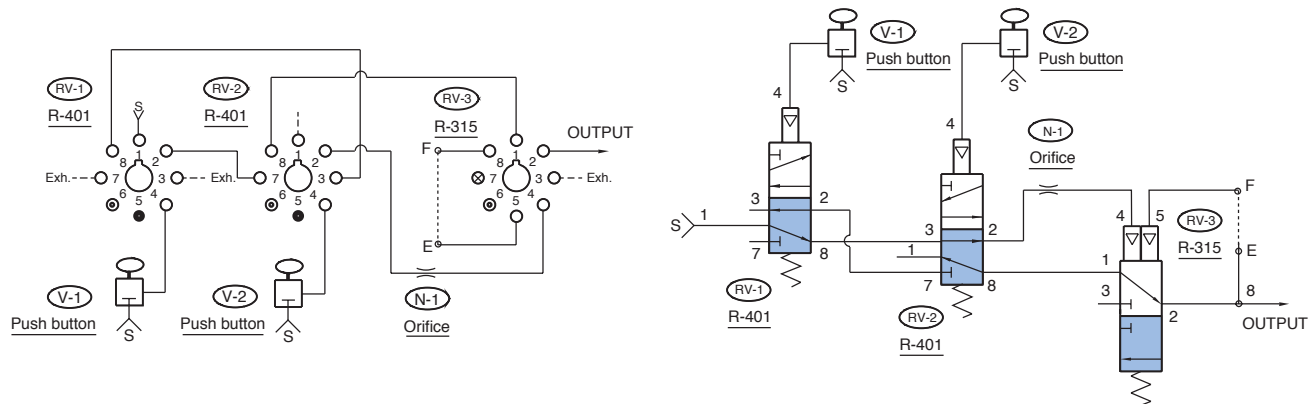

Pilot Signal Priority Lockout

Application of a pilot signal from either push button will pneumatically lock out the output of the other push button to eliminate the possibility of a dual output.

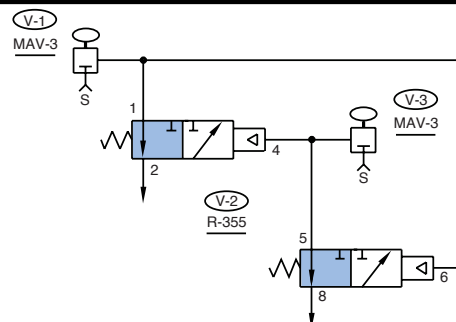

932 Sequence Control Circuit

A typical sequence circuit is shown below. It includes five R-932 sequence modules, two R-402 4-way modular valves, (power valves) and two cylinders, each equipped with two limit valves. This typical circuit is designed for Cylinder A to extend and return, then Cylinder B to extend and return.

In inactive mode, LVA- and LVB- are held passing, supplying pressure to port 8 of both SM3 and SM5. The valves will not actuate because there is air already at port 6 which connects to a larger pilot.

When the start button is actuated, pilot pressure is applied to SM1, shifting the valve which pressurizes port 4 of power valve "A" (PVA) pressure at its port 4. This shifts PVA, extending the cylinder. When SM1 shifts, it also removes pressure from SM2 at port 6 preparing it for step 2.

Extension of cylinder A actuated LVA+. This shifts SM2, providing pressure to port 6 of PVA which shifts and powers the retraction of Cylinder A. The shifting of SM2 also removes supply from port 4 of step 1 allowing the cylinder retraction, and removes supply from port 6 of SM3, preparing it for step 3.

As a result, when LVA- attains passing position this time, there is no pressure on the larger pilot of SM3. It shifts, providing supply to port 4 of PVB. The power module shifts, with resultant flow extending Cylinder B. The sequence cycle continues through retraction and stops unless the start button remains actuated. Continuous cycling can be accomplished by using a toggle or selector valve for the start button.

Retraction of cylinder B actuates LVB- causing a chain reaction for resetting the sequence valves for the next cycle.

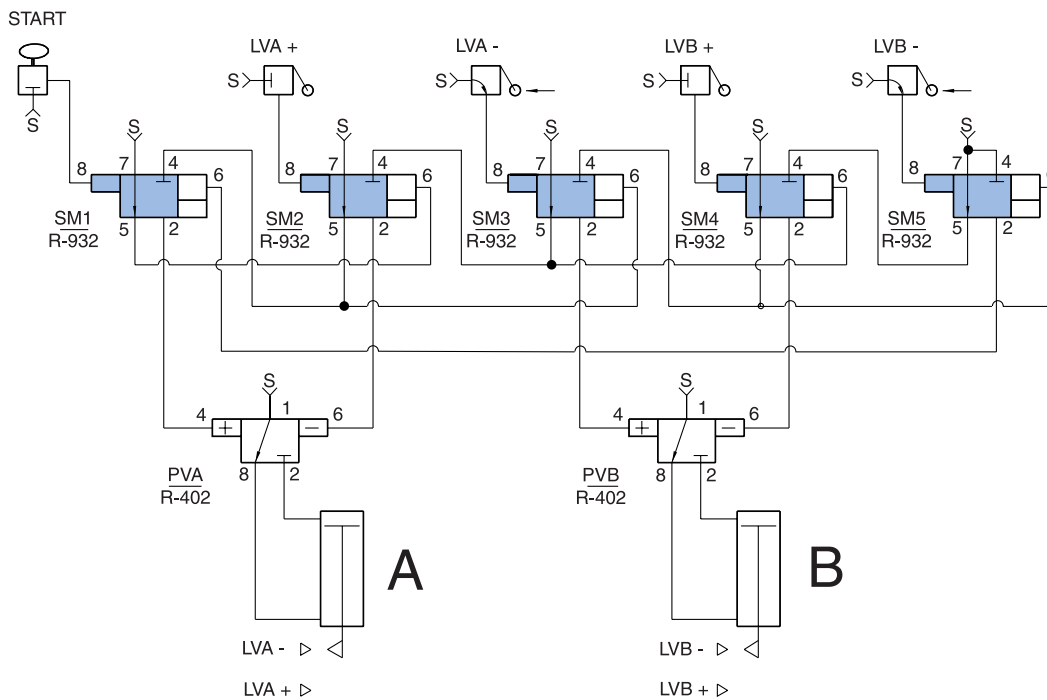

NOTE: The SEQUENCE IS FOLLOWED by the indicator in the valve. The last indicator down is the last step actuated. This is helpful when trouble shooting a circuit.

The circuit described above is an example of a typical sequence circuit. Most applications will require additional functions. Therefore, the number of sequence valves will increase, but the procedure for connections and applications of the R-932 remain.

It is important to remember the input signals can come from other types of input devices such as:

proximity sensors, gap sensors, back pressure sensors, pressure sensors, limit valves, electronic Hall Effect sensing, liquid level sensing, part sensing, etc.

By using modular components found in this catalog, additional functions such as "Delay IN (R-333) "AND" (R-301) can be added to the sequence circuits.

The sequence circuit can also be used with larger air power valves or air piloted hydraulic valves.

Bleed Piloted 4-Way Valve

Pressure in line 4 pilots valve V2 so that the cylinder is retracted on the valve V-2 and C-1 retracted. When V-1 is actuated, the pressure is exhausted from 4 faster than the restricted supply at 5 can make it up. The spring then shifts the valve and C-1 extends.

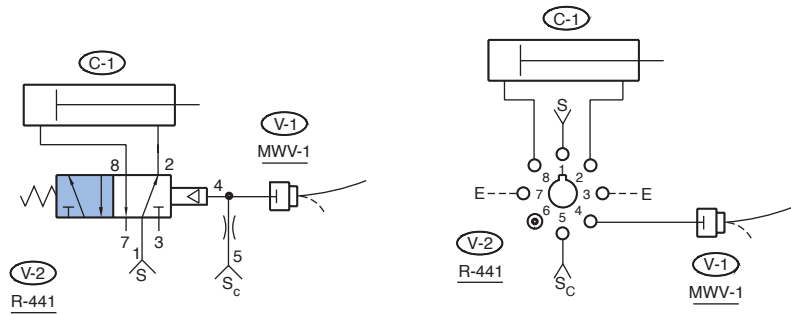

Unique OPEN-CLOSE Pulse Circuit

This pulse circuit can be adapted to a wide variety of uses. It consists of an MAV-3 3-way valve and two standard R-341 modular valves, and is being used to open and close a collet vice on a milling fixture. Circuit operation: when V-1 is depressed, V-2 gives an output pulse at "A". The length of the pulse is predetermined by the needle valve adjustment on V-2.

When V-1 is released, a pulse occurs at "B".

This pulse is also determined by the length of the needle valve on V-3. Thus both pulses are independently adjustable. Note that the R-341 allows supply to be segregated from the pilot signal which allows for different pressures or gases to be controlled.

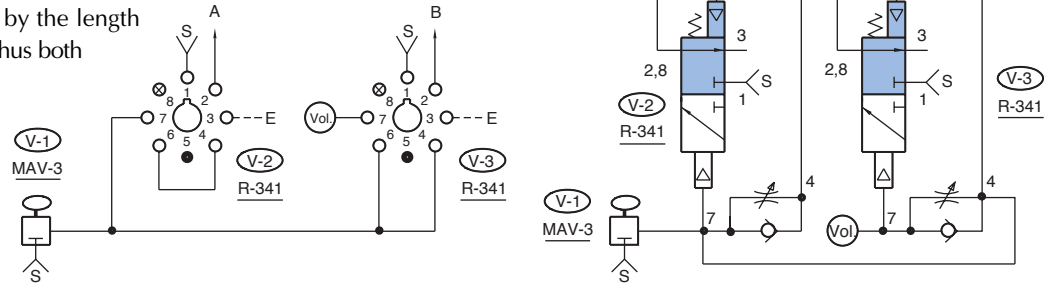

"Latch" Circuit

Actuation of V-1 pilots V-3 and extends C-1. The same pressure that extends C-1 also passes through V-2 and holds the twin pilot down locking C-1 in the out position even though V-1 is released. When V-2 is actuated, breaking the line between port 2 & 5, V-3, and exhausting the pilot, the spring will shift the valve V-3, causing C-1 to retract.

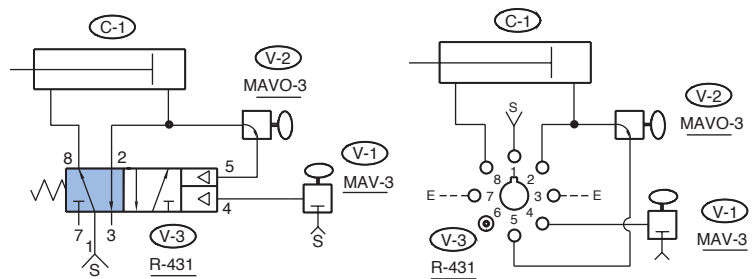

"Active Or" Circuit

Actuation of any one or all of the input signal valves, V-1, V-2, V-3, V-4, will cause an active output (an output from a separate air supply source).

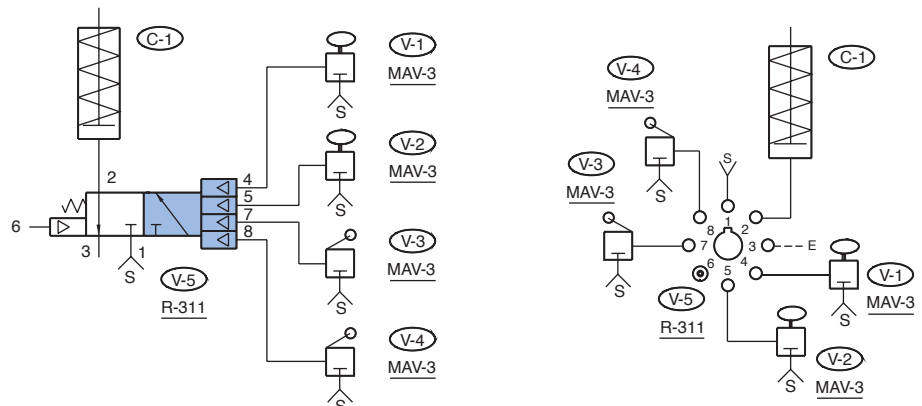

Assembly Jig Control

This circuit is used with an assembly jig that draws a vacuum on a part inserted into it. When the operator has finished working on the part, a spring return knock out cylinder pushes the part out of the jig. Depressing V-1 pilots V-3 which draws a vacuum on the jig. Releasing V-1 allows the spring in V-3 to shift the valve, connecting air to V-2, an adjustable pulse valve, which gives a controlled pulse of air to the knock out cylinder in the jig.

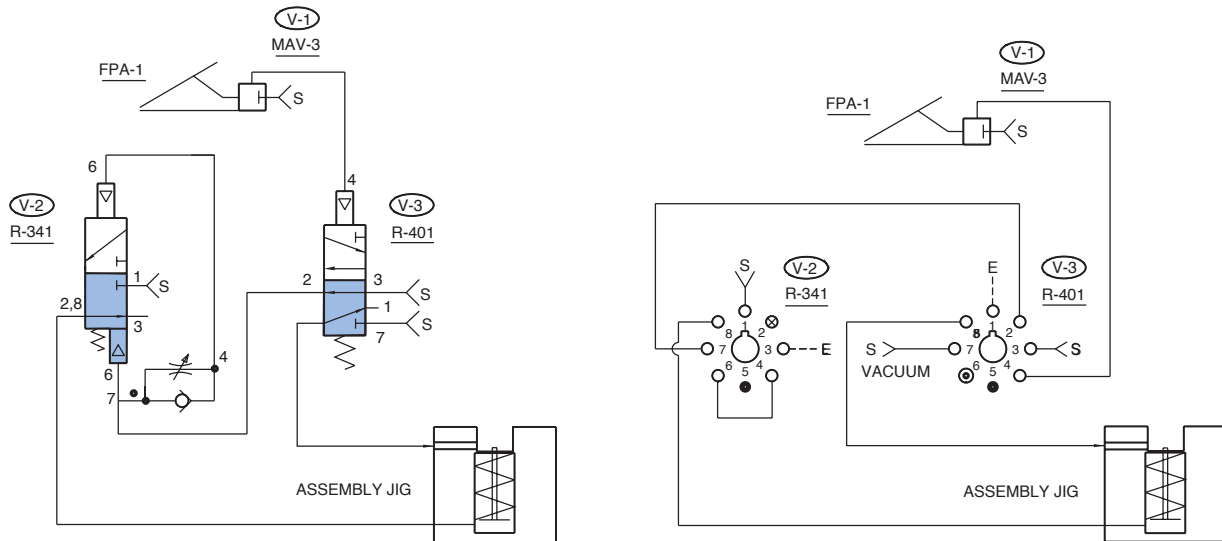

Piloted 4-Way Valve

When V-1 is actuated, pressure forces the pilot to overcome the spring and shift the valve V-2, causing C-1 to retract. Releasing V-1 exhausts the pressure on the pilot and allows the spring to shift the valve extending C-1.

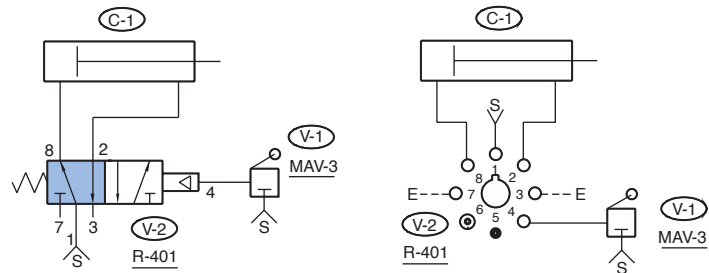

Automatic Cycler

Turning on the toggle switch V-1 sends a signal through V-2 and to the flow control of V-3 where it is delayed before piloting the 3-way (normally closed) valve V-3, which extends C-1. The output of V-3 also goes to the flow control of V-2 where it is delayed before piloting the 3-way (normally open) valve V-2. When V-2 shifts, it shuts off the original signal from V-1 and exhausts the pressure that has piloted V-3, allowing the spring to shift the valve. This causes C-1 to retract and also exhausts the pressure that has piloted V-2, allowing the spring to shift the valve. This allows the signal from V-1 to start the cycle over again. The adjustment on V-3 controls the "IN" duration, and the adjustment on V-2 controls the "OUT" duration at C-1.

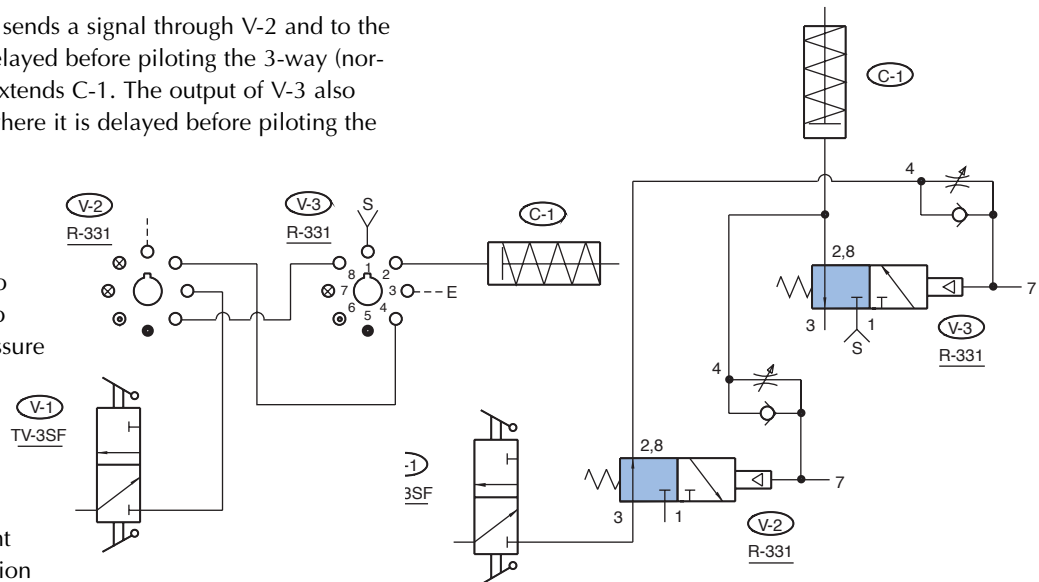

Adjustable Pulse Valve

The R-341 delay valve may be used to provide an adjustable pulse (N.C.) or adjustable off (N.O.) signal. When an input occurs at port 7 it immediately pilots the valve and gives a signal at ports 2 & 8, which extends C-1. The same input is also being delayed through the flow control (between 7 & 4) until enough pressure builds up to actuate the auxiliary pilot which, together with the spring, overcomes the opposite pilot and shifts the valve shutting off the output. C-1 then retracts. The input must be removed before the valve will reset and cycle again. Since the input is separate from the supply and output valving, separate pressures or fluids can be used in the valve. Pulse times can range from 25 MS to 5 seconds. The second drawing shows the R-341 piped normally open. The same sequence applies as above, only the valve is going off for a period instead of on.

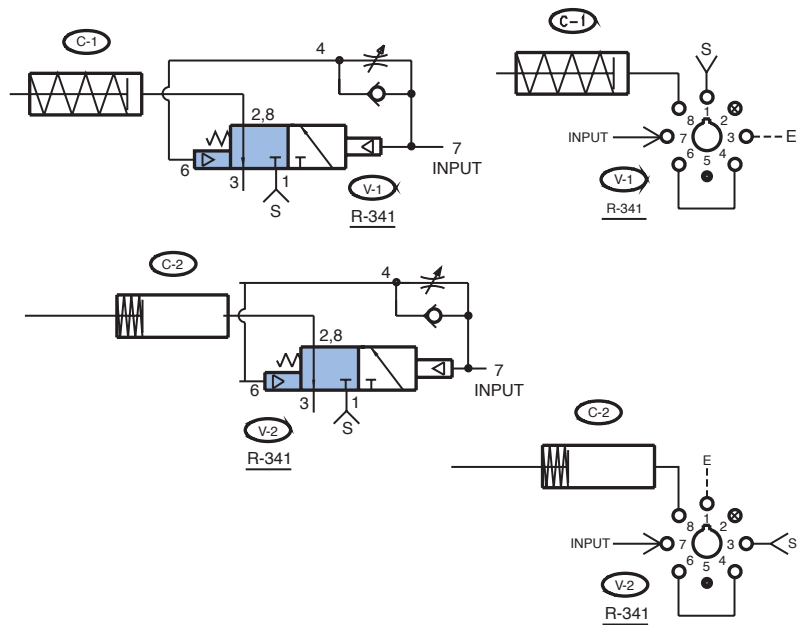

Set-Reset Circuits

Shown are three examples of set-reset circuits, also called "latch" circuits. There are many ways to set or reset a valve or group valves. These examples make use of the unique auxiliary pilots available on many of the modular valves.

A set occurs when a valve is actuated and part of the output is used to hold the valve in the actuated position, even though the original pilot signal may be gone.

Generally a circuit is reset by interrupting the "set" pilot line or air supply to the valve when an opposite pilot is present to shift the valve. The modular auxiliary pilot, in combination with the valve spring, will overcome any or all opposite pilot(s) to reset the circuit.

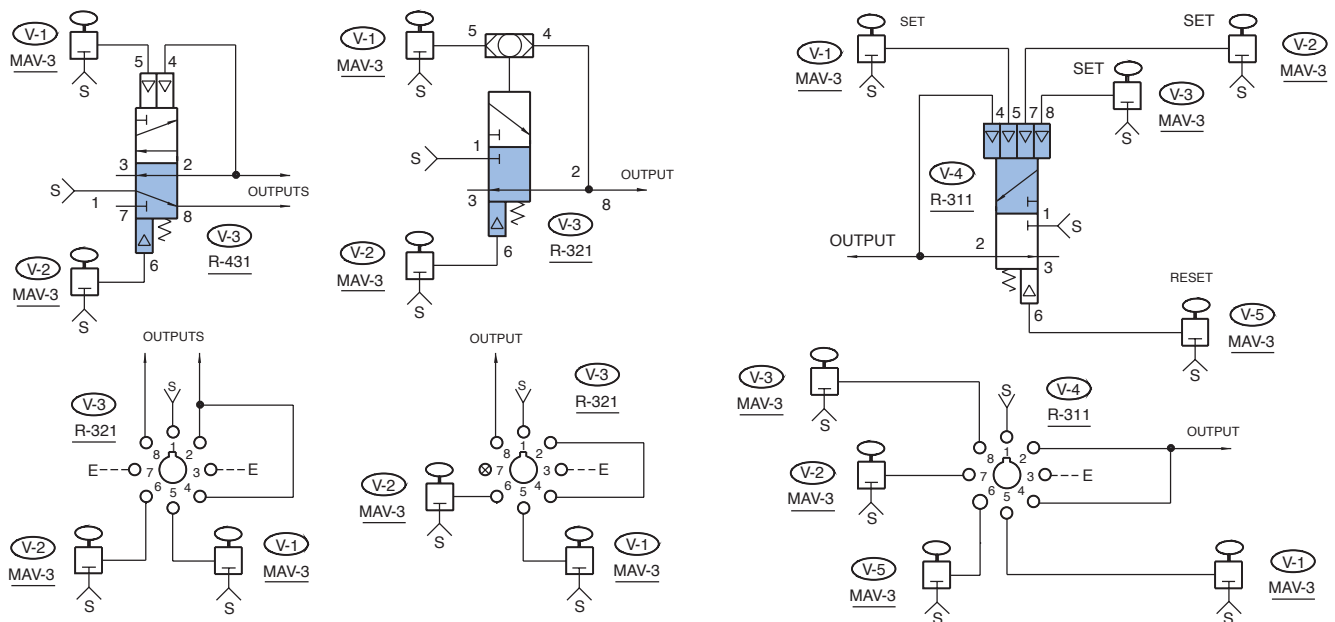

Six Ported 4-Way

This circuit controls two double acting cylinders with a single 4-way (6 ported) valve. When V-1 has been depressed, actuation of V-3 will extend or retract C-1. When V-2 has been depressed, actuation of V-3 will extend or retract C-2.

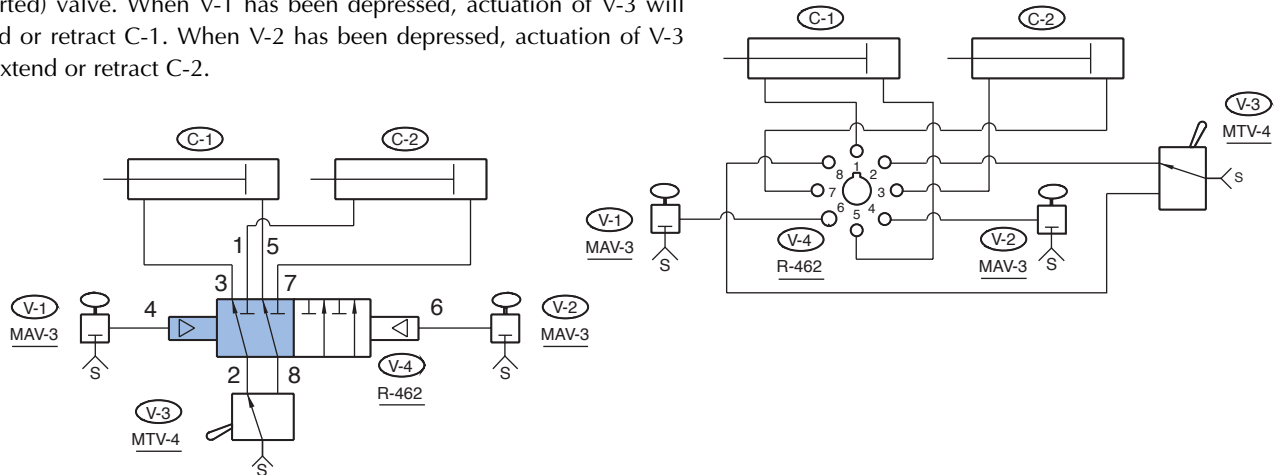

Three Input "And"

The R-353 valve will give an output at C-1 only when V-1, V-2, and V-3 are depressed. Remove any of the three inputs and the output ceases.

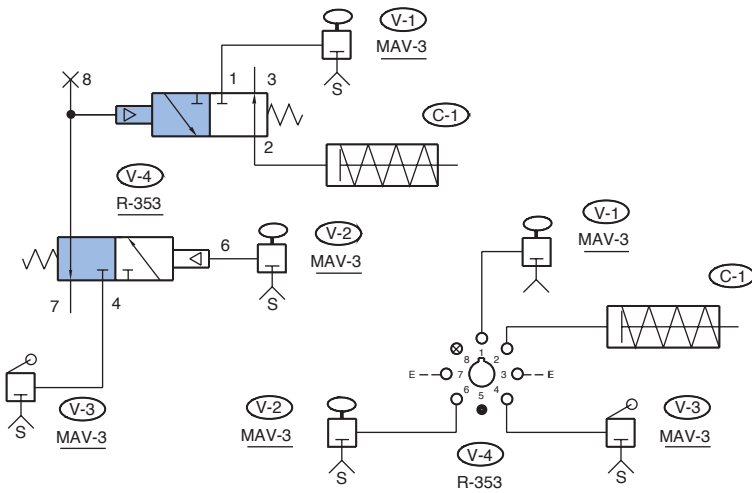

Exhaust Piloted 3-Way Valve

Pressure in line 7 holds pilot down on the valve V-2 which has no output signal. When V-1 is actuated, pressure is exhausted from line 7 faster than the adjusted supply can make it up. The spring then shifts the valve giving an output at ports 2 & 8. (Port 8 is shown as blocked.)

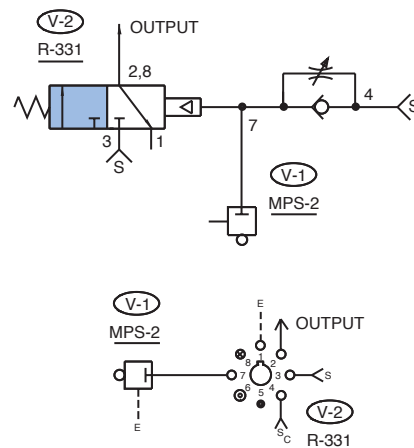

Piloting From Two Inputs

Actuating of either V-1 or V-2 will pilot V-3 causing C-1 to extend. The R-321 is shown normally closed. It may also be used normally open, as a selector, or as a diverter. An R-315 provides the same function by having two separate pilots.

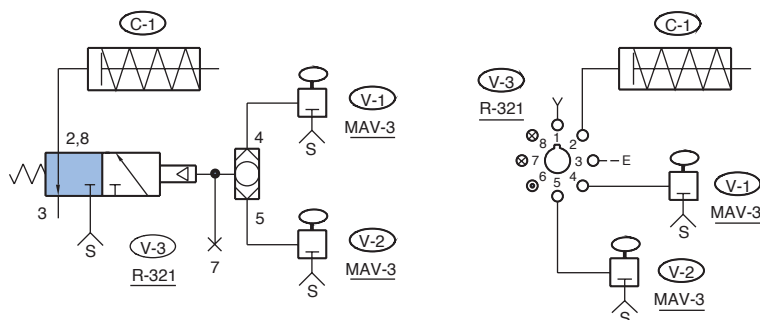

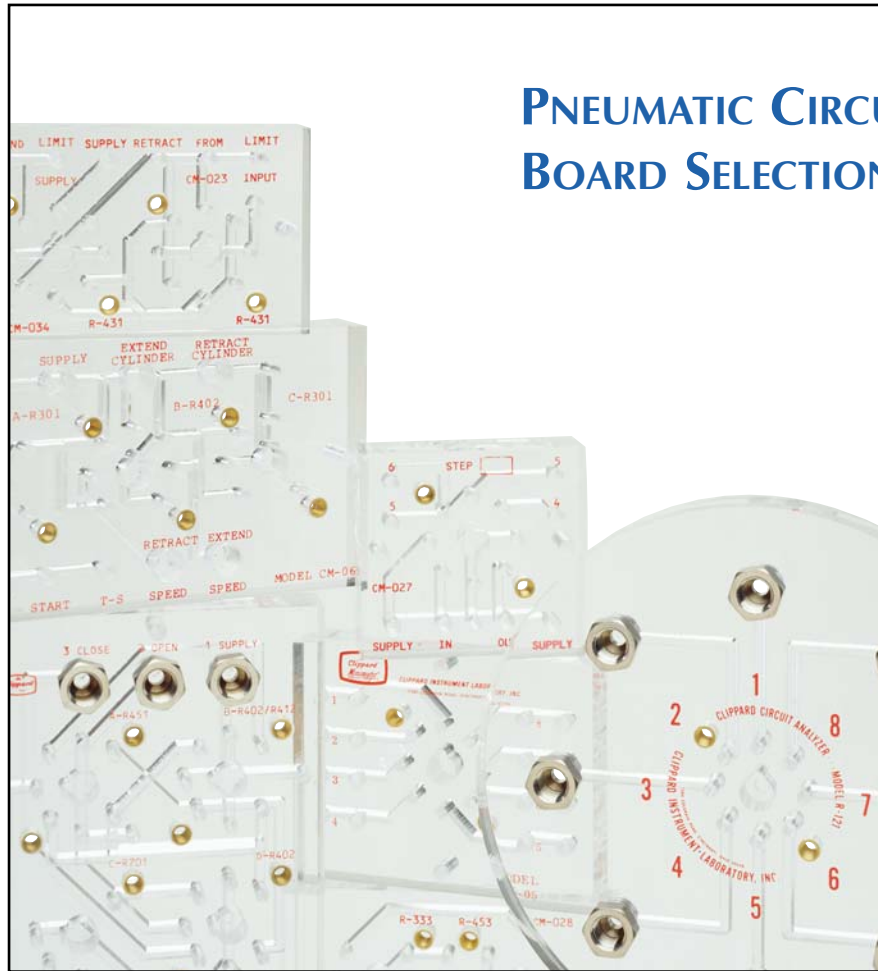

PNEUMATIC CIRCUIT BOARD SELECTION GUIDE

- | | | | |
|--------|--|--------|---|
| CM-01 | Circuit Analyzer | CM-024 | Sequencing Circuit, 5 step |
| CM-02 | Adapter Manifold, 1/8" NPT | CM-025 | Sequencing Circuit, 2 step |
| CM-03 | Binary Circuit | CM-026 | Sequencing Circuit, 3 step |
| CM-04 | Adapter Manifold, #10-32 Single | CM-027 | Sequencing Circuit, 1 step |
| CM-05 | Adapter Manifold, #10-32 Dual Ports | CM-028 | Oscillator, Double Acting |
| CM-06 | Auto Cycling | CM-030 | Auto Cycling, Input / Output Flexibility |
| CM-07 | R-471 / R-481 Manifold, Single | CM-031 | Auto Cycling, Enhanced Flexibility |
| CM-08 | Binary Clamp Control | CM-033 | Auto Cycling Control for External Power Valve |
| CM-010 | Double Electronically Piloted Valve | CM-034 | Latching Circuit For Two Hand No Tie Down |
| CM-011 | Oscillator, Single Output | CM-035 | Sequencing Circuit, 4 step |
| CM-016 | 4 Valve Manifold, 4-Way | CM-036 | Adapter Manifold, 2 Valves |
| CM-018 | Double Electronically Piloted Valve, Closed Center | CM-037 | Adapter Manifold, 3 Valves |
| CM-019 | R-471 / R-481 Manifold, 4 Valves | CM-038 | Two Hand No Tie Down with Latch Circuit |
| CM-020 | R-471 / R-481 Manifold, 6 Valves | | |
| CM-023 | Two Hand No Tie Down | | |



FEATURES & BENEFITS

Circuit Boards and Clippard Modular Components



Clippard clear acrylic pneumatic circuit boards are designed to provide a compact and highly efficient pneumatic control system, with the use of Clippard modular components and other Clippard products.

Many valving systems require a considerable amount of piping, tubing and fittings to create the necessary circuitry. The piping originates beneath the valve and often needs extra space and clearance to complete. The acrylic circuit board provides a place to mount the components and easy methods to hook-up the circuit, generally on the top side of the circuit board. For a single circuit the original assembly method can be the best direction to take... but where a number of identical circuits are prepared, the acrylic circuit board technology offers a series of distinct advantages.



In addition to the Clippard modular line of products, the circuit boards also accommodate Clippard EV/ET manifold mount valves, and many other valves, gauges, mufflers, as well as hose barb fittings. The combination of Clippard pneumatic circuit boards, valves, fittings, and accessory items can provide a complete pneumatic circuit system with the knowledge of dependability and success.

FEATURES

- Custom-made pneumatic circuit boards hold all components
- Simplifies assembly
- Reduces piping
- Helps assure accuracy of connections
- Component I.D. silk-screened on subplate surface
- Inputs and outputs clearly marked
- Threaded brass inserts hold components securely
- Change valves quickly without affecting connections
- Use any number of components
- Makes sophisticated circuitry manageable
- Circuit boards also accept Clippard electronic interface valves
- Saves assembly costs

Pneumatic Circuit Boards

This section provides detailed information about a series of circuit boards for popular uses. These range from the very simple single-module circuit, to more complex multi-step sequencing circuits using pneumatic control to automate machine or process cycles. The descriptive materials include photographs, dimensional drawings, circuit diagrams where applicable, lists of products required, and descriptions of the function of the circuit.

The circuit boards included in our price list are maintained in stock with our [distributors](#) and/or in our finished goods inventory at our factory. They are available for fast delivery.

For assistance in selecting a circuit board to suit your use, ask your local Clippard [distributor](#) to discuss your application.

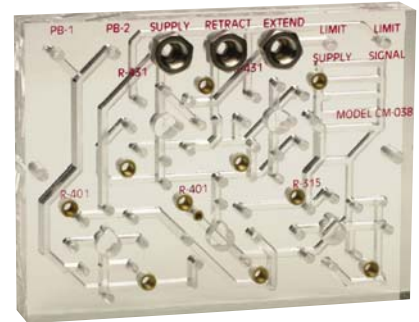

Custom Pneumatic Circuit Boards

You can have a faster, more dependable way to produce multiples of the same pneumatic circuit . . . a system that enables you to speed circuit assembly while assuring accurate hookups.

Using Clippard modular components, valves and controls mounted on a custom circuit board, you get the same circuit time after time.

Assembly time and effort are reduced. A large number of parts, fittings, and lengths of tubing are no longer needed. The resulting circuit is compact, neat in appearance, and

can be easily mounted for permanent installation. No more “haywire” plumbing. Piping errors are eliminated, and an efficient, dependable, and attractive control results.

Each custom circuit board is individually produced with the same high quality standards associated with the Clippard name. By utilizing Clippard’s unique manufacturing process, these clear acrylic units provide sealed internal passageways between valves without the need for gaskets, clamps, or piping.

Sizes and dimensions will vary according to your application. By adapting your control requirements to the versatility of Clippard Modular Valves, your Clippard [distributor](#) can provide you with detailed application information.

To complete your pneumatic control, just plug in the modular valves and tighten the two captivated screws on each valve. Connect inputs and outputs to the circuit board and the circuit is ready to run. It’s the fastest most efficient circuit system available.





STANDARD PNEUMATIC CIRCUIT BOARDS

CM-01

Circuit Board for Octoport Circuit Analyzer

Size: 6 5/16" dia. by 3/4" thick. Holds one module - plus 8 Clippard pressure gauges

Use: For testing and to analyze Clippard modular valve circuits. To order circuit board only: specify part #CM-01

To order analyzer complete with pressure gauges, hose and connections, specify Part # R-121.

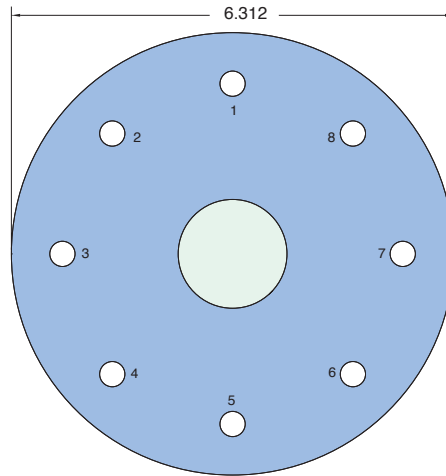
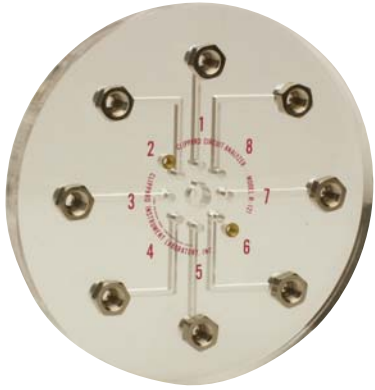

CM-02

Adapter Circuit Board Single Module

Size: 3 1/2" x 3" x 9/16" - 1 module

Use: Provides mounting for a single modular valve, with 8 individual 1/8" NPT ports furnished on the top side of the circuit board. Beneficial in experimenting or bread boarding a new circuit or one operation of a circuit. You can quickly connect input and outputs on a temporary basis, and check operation of the module through results and pressures resulting at the various valve ports. Test several modules by merely unplugging one, and replacing it with another. Just two screws to loosen. All connections are automatically made. Suitable for building a one module circuit. Very compact size. Easy to mount. Light weight. Valves are easily replaced.

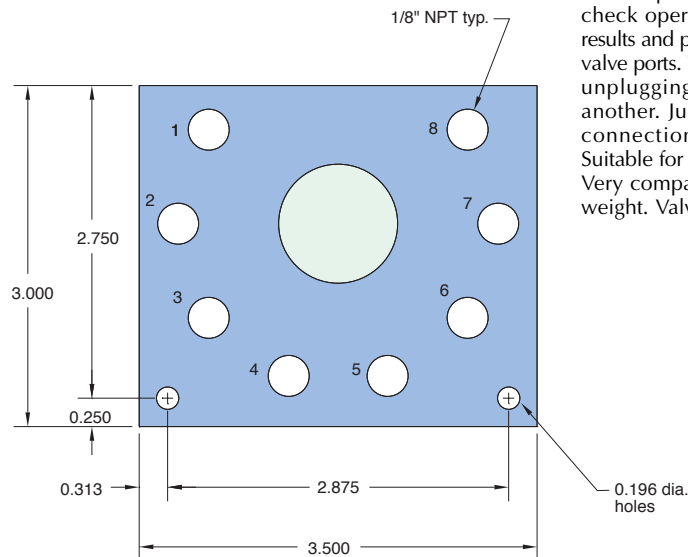



CM-03

Binary Redirect Circuit Boards

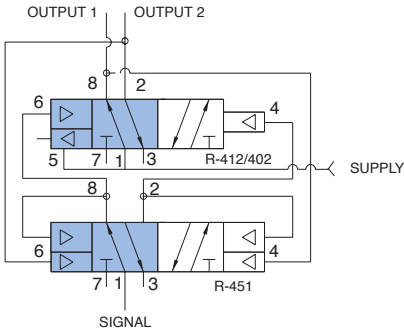

Size: 4 1/2" x 2 3/4" x 13/16" thick - 2 modules

Use: Combines the R-451 and R-402 or R-412 in a binary redirect or flip-flop circuit. Provides 1/8" NPT ports or 1/4" tube push quick fittings for all connections.

Operation: Use of the R-412 provides a "memory" function to return the output to a known position (port 8) whenever air is first turned on to the circuit. This output pilots port 4 of the R-451 positioning it for the next signal. A signal input passes through the R-451, ports 1 to 2, and pilots port 4 of the R-412. The output of the R-412 shifts to port 2 and also pilots port 6 of the R-451. When the next signal input is received, it passes through the R-451, ports 1 to 8, and pilots port 6 of the R-412, shifting its output back to port 8.

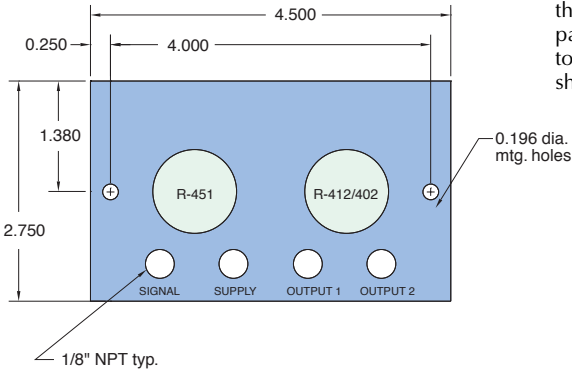

CM-04

Universal #10-32 Circuit Board

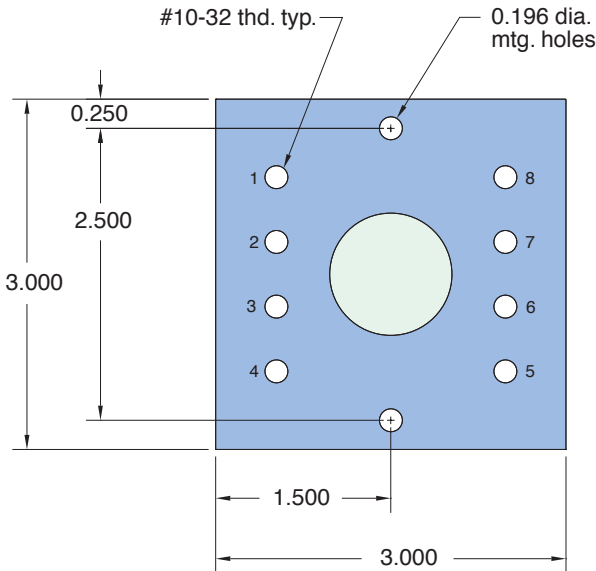

Size: 3" x 3" x 5/8" thick - 1 module

Use: Provides mounting for a single modular valve, and provides #10-32 ports on the top side of subplate. Similar to CM-02, but ports are #10-32 threaded instead of 1/8" NPT.

Handy for circuit development and single module circuits

CM-07

Circuit Board for R-471/472/481/482 with 1/8" NPT Ports

Size: 4" x 2 3/4" x 5/8" thick - 1 module

Use: Port #4, the supply to the pilot valve, is connected to the main supply port #1. Provides 1/8" NPT ports in the top of the circuit board.

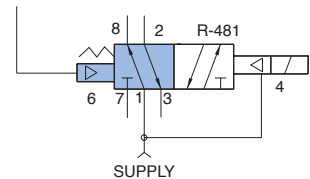
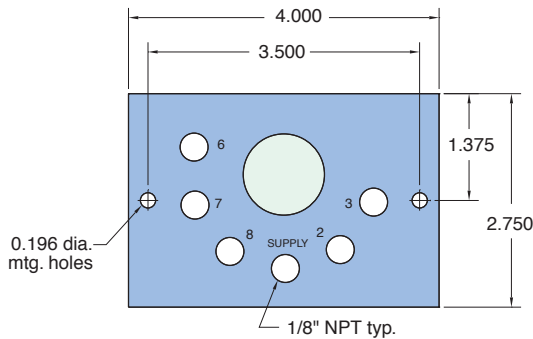

CM-08

Circuit Board for Binary Clamp Control with Adjustable Clamp Pressure

Size: 4" x 7" x 1" thick - 4 modules plus controls and fittings
Just PUSH for "On"
Just PUSH for "Off"

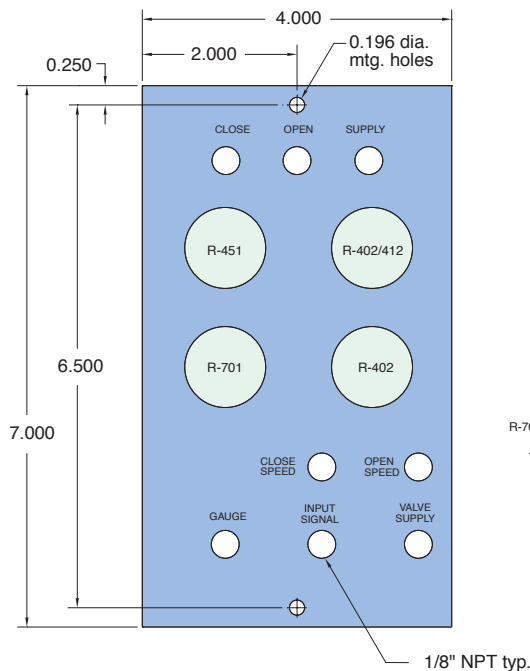

The Clippard CM-08 circuit board and the control valves that mount on it form a single push button pneumatic "OPEN/CLOSE". Binary clamp control with pressure and speed controls. The components are sold separately and can be assembled in a few minutes by the user. The use of this CM-08 package offers special user benefits: saves time; reduces cost and labor of piping; automates product tasks with easy to apply unit; binary push button operation; speed control built-in; pressure regulation included; may be operated remotely; equipped with "Auto-Reset" feature.

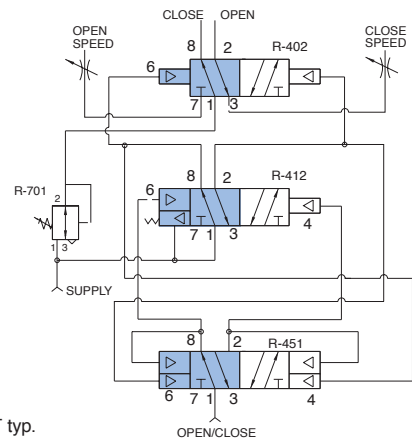

CM-010

Circuit Board for Double Electronic Piloted Valve

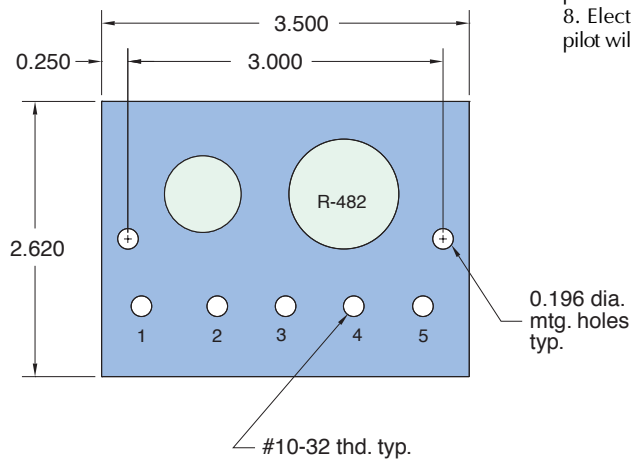
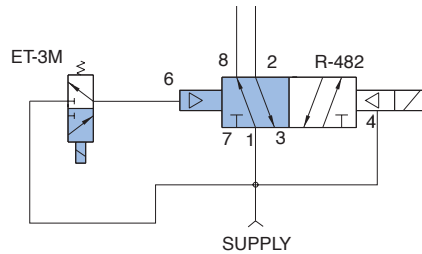

Size: 3 1/2" x 2 5/8" x 5/8" thick - 1 module and one ET-3M-xx valve

Use: Provides mounting for one R-482 solenoid operated valve and one ET-3M valve for a double electronic piloted control circuit.

Operation: Supply air passes to ports 1 and 4 of the R-482 and to the supply port of the ET-3M valve. Starting position of R-482 may vary. Electronic signal to ET-3M will pilot port 6 of R-482 giving output at port 8. Electronic signal to the R-482 ET pilot will shift valve to output at port 2.

CM-011

Circuit Board for Autocycling of Single Acting Cylinder

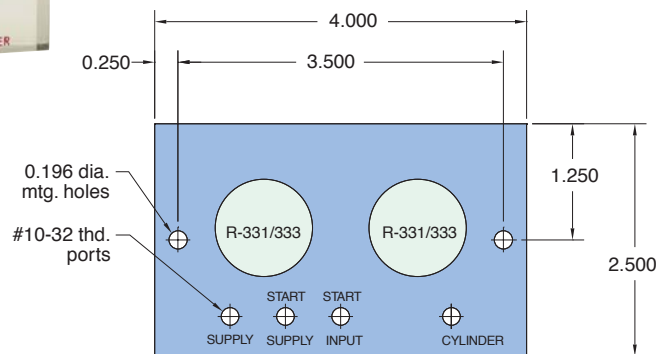
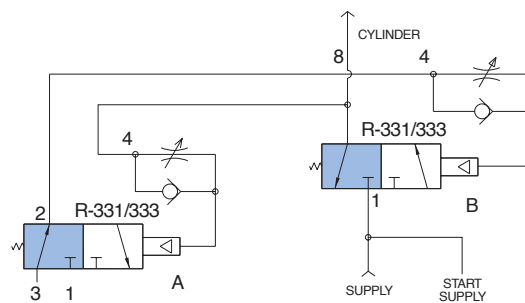
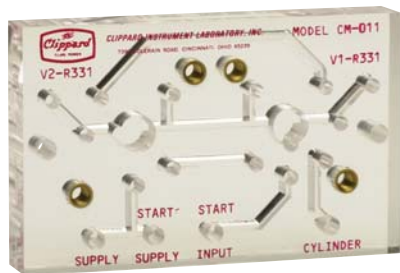

Size: 4" x 2 1/2" x 9/16" thick - 2 modules

Use: Provides mounting for two R-331 or R-333 modular valves. Circuit provides for automatic cycling of the two modular valves. The needle valve adjustments in the modular valves allow for controlled on/off delay signal providing variable cycle speed.

Operation: With no start input, cylinder will remain in retracted position. Turning on the start input signal causes valve "A" to output from port 2 to port 4 of "B". This signal is restricted in and pilots "B" to shift. When "B" has shifted, air flows through "B" from port 1 to 2 extending the cylinder. This output also goes to port 4 of valve "A" and is restricted in. When sufficient pressure builds to shift "A", the output of "A" drops out exhausting the port 4 pilot of "B" which allows the cylinder to retract to the starting position. Adjustment of the respective flow controls allows individual frequency controls of the extend and retract strokes.

CM-016

4-Way Valve Circuit Board (Common Supply)

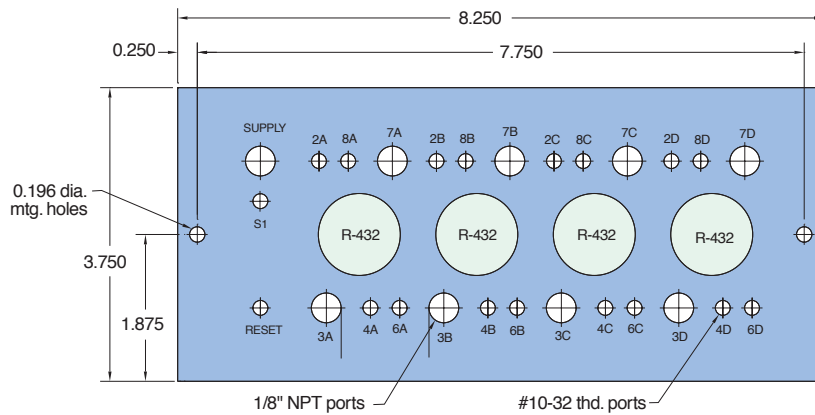

Size: 3 3/4" x 8 3/16" x 9/16" thick - 4 modules

Use: Provides mounting for four 4-way modular valves operating from a common supply. May utilize Clippard [R-401](#), [R-402](#), [R-405](#), [R-410](#), [R-412](#), [R-421](#), [R-431](#), [R-432](#), [R-441](#), or [R-442](#) valves. Supply and exhaust are tapped 1/8" NPT. Outputs are #10-32 tapped ports in the circuit board.

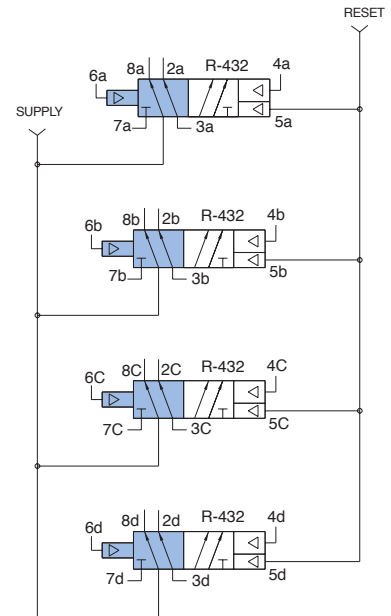

CM-018

Circuit Board for Double Electronically Piloted 4-Way Valves

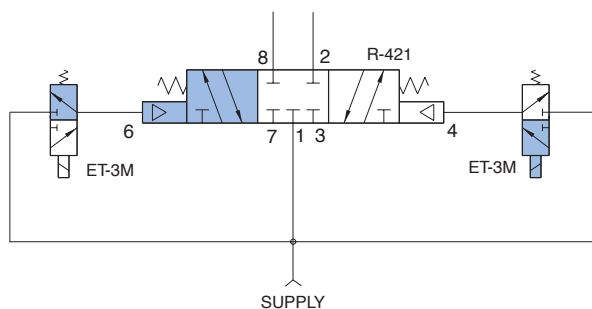

Size: 2 5/8" x 4 3/4" x 9/16" thick - 1 module;
2 ET-3M-xx valves

Use: Provides mounting platform for one [R-402](#), [R-412](#) or [R-421](#) pneumatically operated valve and two ET-3M valves for a double electronic piloted control circuit

Operation: Supply air passes to port 1 of the [R-421](#) and to supply ports of the ET-3M valves. [R-421](#) is a three position, center closed valve, spring centered. Electronic signal to either ET-3M will pilot [R-421](#) giving corresponding output as long as that ET valve remains energized. Energizing both ET valves simultaneously will cancel out opposing pilots. Springs will return [R-421](#) to center-closed position.

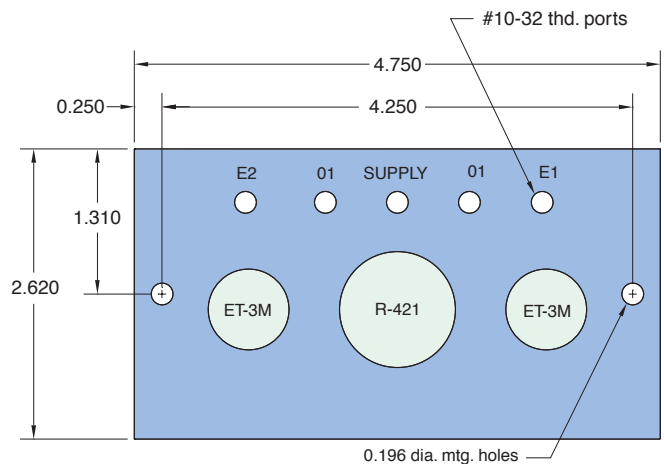



STANDARD PNEUMATIC CIRCUIT BOARDS

CM-019

Circuit Board for 4 R-471/481 4-Way Valves

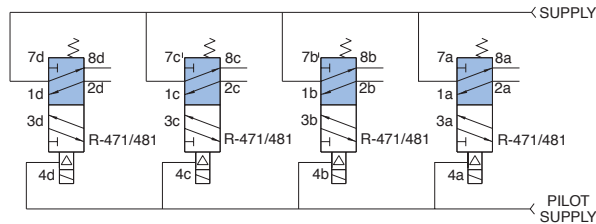

Size: 3 1/4" x 8" x 9/16" thick - 4 modules

Use: Convenient and compact mounting for a group of four electronically piloted or low pressure piloted 4-way modular valves. Separate main valve supply and pilot supply #10-32 ports provided for access to exhaust for speed control.

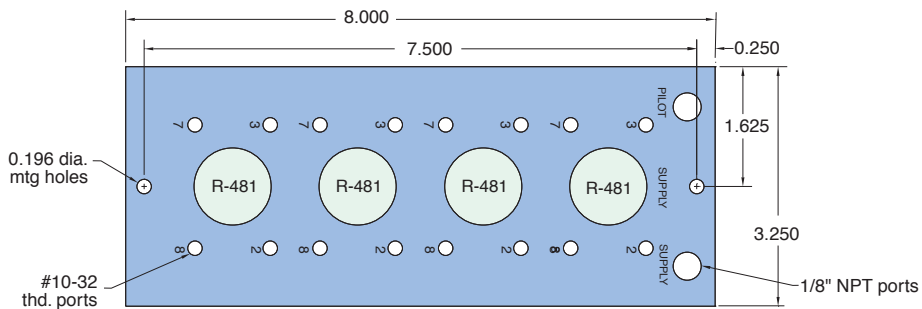

CM-020

Circuit Board for 6 R-471/481 4-Way Valves

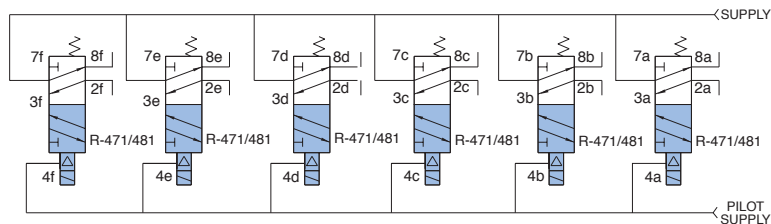

Size: 3 1/4" x 11 1/2" x 9/16" thick - 6 modules

Use: Convenient and compact mounting for a group of six electronically piloted or low pressure piloted 4-way modular valves. Separate main valve supply and pilot supply for solenoids. #10-32 ports provided for access to exhaust for speed control.

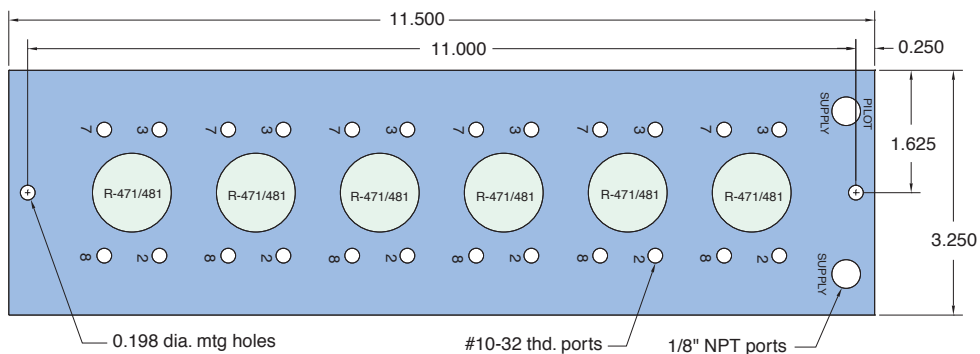

STANDARD PNEUMATIC CIRCUIT BOARDS

TWO HAND NO TIE DOWN



The Clippard Minimatic® CM-023 pneumatic circuit board is a self-contained modular circuit board with all interconnections needed to provide a two hand no tie down (THNTD) pneumatic circuit. The board is designed to be used with three Clippard modular plug-in control valves and to eliminate the piping time and materials normally associated with circuitry. Use of the CM-023 will assure simple and rapid installation of your two hand no tie down circuit.

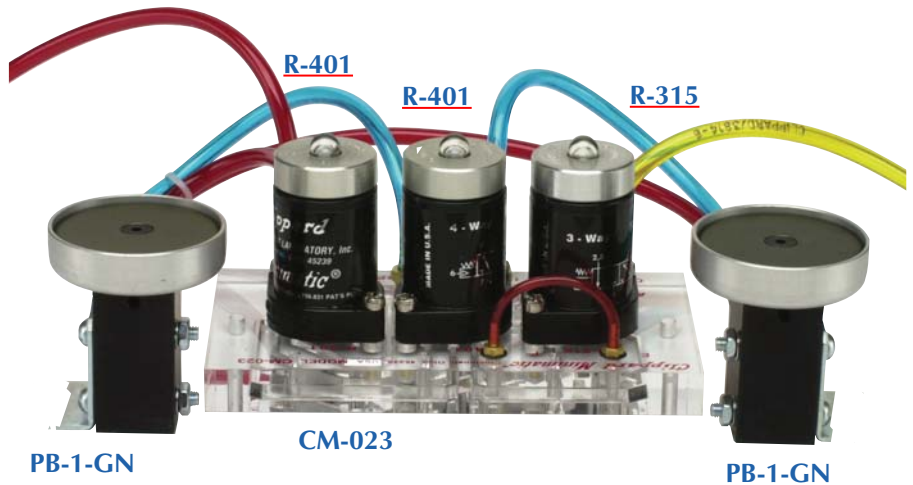

The CM-023 THNTD control circuit requires two separate input signals that must be received approximately at the same instant before an output signal is obtained. Both input signals must be spontaneous and neither can be "tied down" or made constant. The main function of this control is to require a machine operator to use both hands to actuate the machinery, helping to insure that the operators hands are not in a position to be injured by the machine as it is actuated. When used with the Clippard PB guarded palm button valves which have been properly positioned and mounted, the CM-023 THNTD control will provide an output to actuate machinery only when the operator pushes each button simultaneously.

The growing emphasis on employee safety and governmental regulations requiring safe work conditions have encouraged the widespread use of two hand no tie down controls to protect workers from injury. Numerous types of THNTD controls have been introduced to the market. Many are cumbersome, bulky and expensive. The Clippard Minimatic THNTD package offers ease of installation and maintenance in a compact size.

CM-023

Circuit Board for 2 R-401 and 1 R-315 Valve **Size:** 6 1/4" x 3 1/2" x 9/16" thick - 3 modules
 Warning: See instructions shipped with product

Use: Clippard's Minimatic® CM-023 and CM-023-PQ circuit boards are self-contained modular circuit boards with all interconnections needed to provide a Two Hand No Tie Down (THNTD) pneumatic circuit. Use of the CM-023 or CM-023-PQ will assure simple and rapid installation of your two hand no tie down circuit.

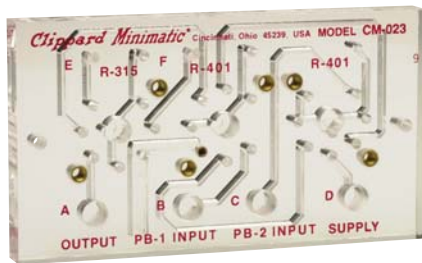

CM-023

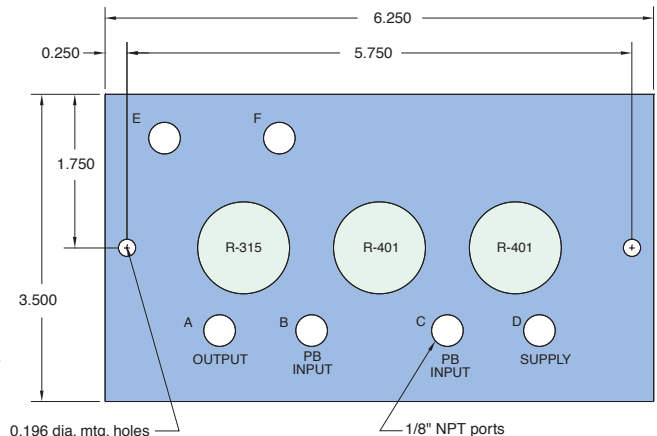
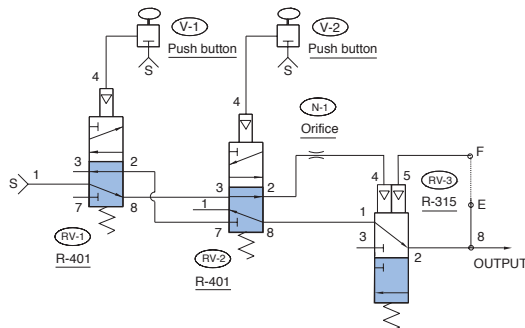



STANDARD PNEUMATIC CIRCUIT BOARDS

TWO HAND NO TIE DOWN

Circuit Operation

RV-3 is held open by supply air that passes through RV-1, RV-2 and N-1. When RV-1 is actuated alone, the pilot air for RV-3 flows back through the N-1 and RV-2 to atmosphere at RV-1 and RV-3 is closed by the spring. When RV-2 is actuated alone, the same sequence occurs except the pilot air from RV-3 exhausts to atmosphere via RV-2. Restriction N-1, which determines the time span during which both signals must be received in order to obtain and output.

When RV-1 and RV-2, are actuated together, supply air is directed through RV-1, RV-2 and RV-3 to the output providing a momentary output signal that is determined by N-1. If a maintained output is required, a jumper between "E" + "F" maintains an output as long as the operator is depressing both palm buttons.

The indicator on RV-3 (R-315) must be down for an output to be obtained. If either RV-1 or RV-2 is actuated separately, their respective indicator will go up, but after approximately one second the indicator on RV-3 (R-315) will go down showing that the valve has shifted and an output cannot be obtained. Circuit performance and sequence should be periodically observed to verify proper function. Absolutely no alterations or modifications should be made to this circuit or its component parts.

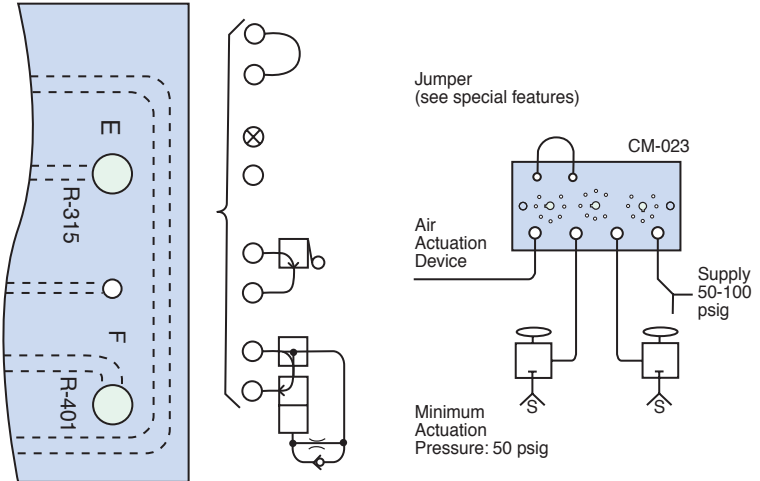

Maintained Output occurs as long as both pushbuttons are held. Release of either button terminates the output. (Connect E to F)

Momentary Output gives a single output pulse that is about 50 MS in duration. (Plug E with 11755 screw plug; F is open)

Cancelable Output terminates the output after a normally open 3-way limit valve has been tripped, even if both pushbuttons are still held. (Interpose normally open 3-way valve)

Cancel Output after Time Delay is a variation of cancelable output (above) where pneumatic delay valve such as Clippard Model R-331 is set to cancel the output after a designated time interval has elapsed. (Interpose normally open 3-way delay valve)

It is the *user's responsibility* to determine which special feature can be safely used in his particular application.

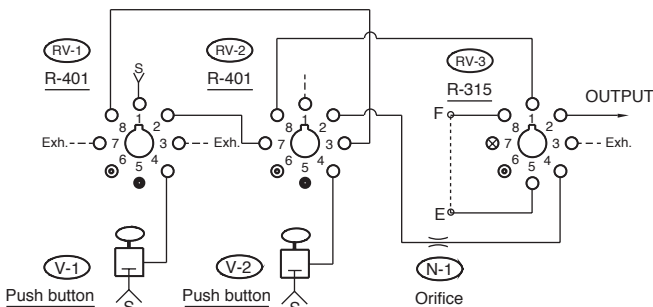
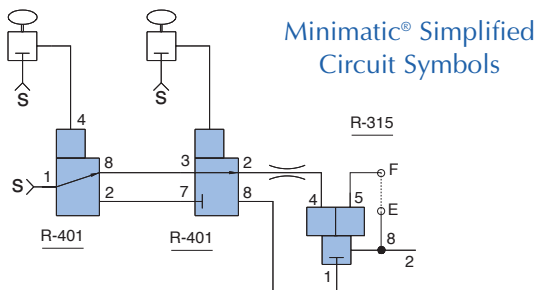

Octoport Piping Diagram

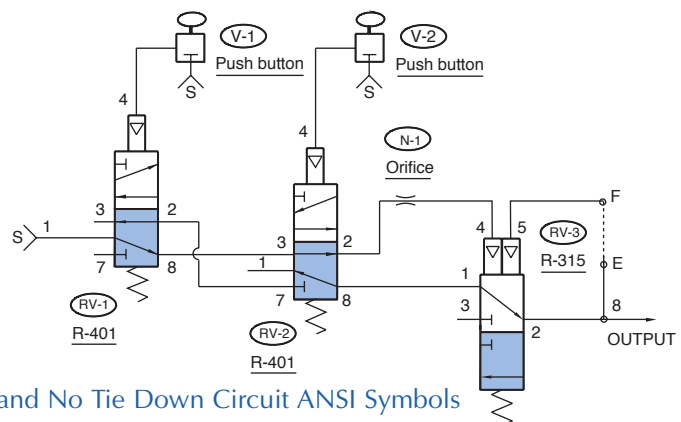

Two Hand No Tie Down Circuit ANSI Symbols

Shown below is a schematic for connecting additional [R-932/R-934](#) stages. This technique would apply if connecting two CM-024's, CM-024 to a CM-026 or a CM-027, or a CM-024 to a CM-025 as shown.

1 The supply into the "supply port" on the CM-024 through the jumper line provides supply to the additional [R-932](#) stage board.

Port 5 on the first CM-024 board and the last additional [R-932](#) must be plugged, (Use Clippard P/N [11755](#) screw plug.)

3 The output of valve 7 on the CM-025 is connected to port 6 on the CM-024. The purpose is to establish the next cycle. The connection from the end port on the additional stage [R-932](#) / [R-934](#) connects to port 4 of that board. This provides pressure to port 6 of CM-024 when valve 7 of CM-025 shifts to the "output" mode. (This is the last step in the cycle.)

Modification of circuits can be easily accomplished by changing the input/output sequence. Refer to the Clippard Designer's Guide for additional information on this unusual and easy to use pneumatic control circuit sequence system.

CM-024

5-Valve Sequence Circuit Board used as the Starter Subplate

Size: 9 1/2" x 2 1/2" x 13/16" thick - 5 modules

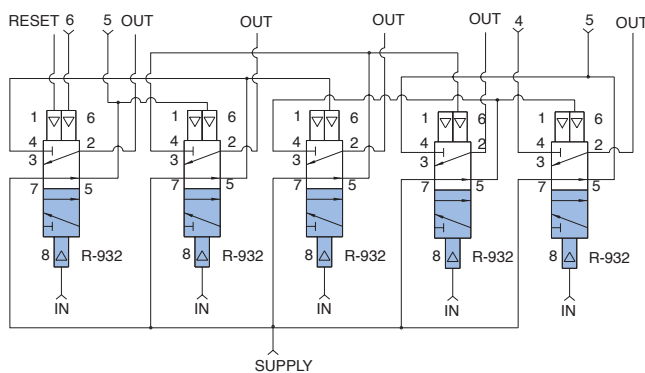

Operation: This five valve sequence circuit board is used as the starter; #10-32 port connections provided for signal inputs, step outputs, reset input, and jumper connections for linking multiple boards together. May be linked to CM-024, -025, -026, -027, or -035 or any combination thereof to achieve sequential steps. 1/8" NPT port provided for incoming supply with #10-32 port provided for linking supply to downstream expander units. In addition, step-by-step input requirements make integration of this manifold, with various others shown in the catalog, quick and easy for development of complex control circuitry.

Use: The [R-932](#) sequence control circuit board is a compact efficient system for integrating sequential control of a multi-step operation. It has many uses throughout industry. For example:

- Metalworking: multiple drilling, tapping, etc. Operation where workpiece must be clamped, worked, released, and transferred in a precise order with no overlapping steps.
- Production: where a unit is sized, wrapped, and cut in proper sequence.
- Assembly: insertion of product in package, closure, and delivery to a conveyor. The CM-024 may be linked to CM-025, -026, -027, or -035 as required to provide additional sequence steps.

Note: Output of last step must be connected to port 6.

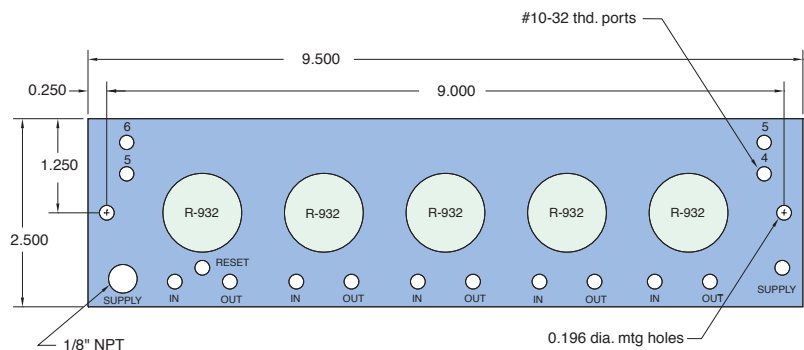

CM-025

Circuit Board for R-932 Sequencing System
Using 2 Modular Valves

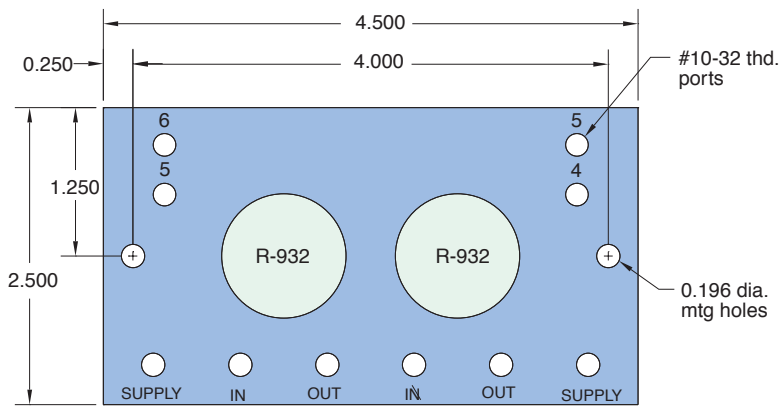
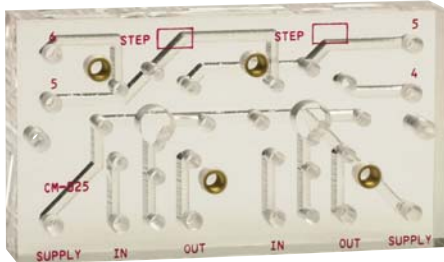

Size: 4 1/2" x 2 1/2" x 13/16" thick - 2 modules

Use: 2-valve sequence circuit board used as an expansion unit. #10-32 port connections provided for signal inputs, step outputs, supply, and jumper connections for linking multiple boards together. May serve as a final segment of circuit or be inserted between two other sequencing circuit board.

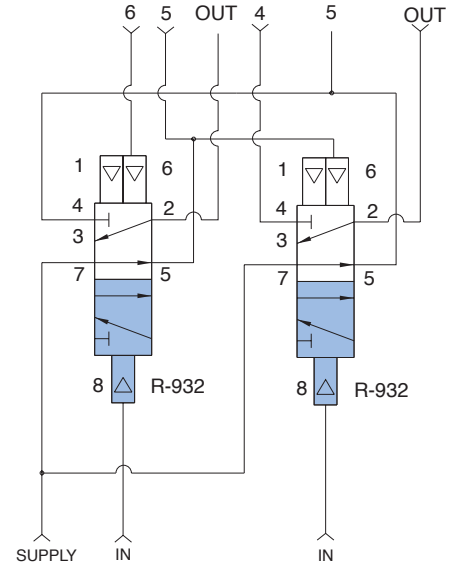

CM-026

Circuit Board for R-932 Sequencing System
Using 3 Modular Valves

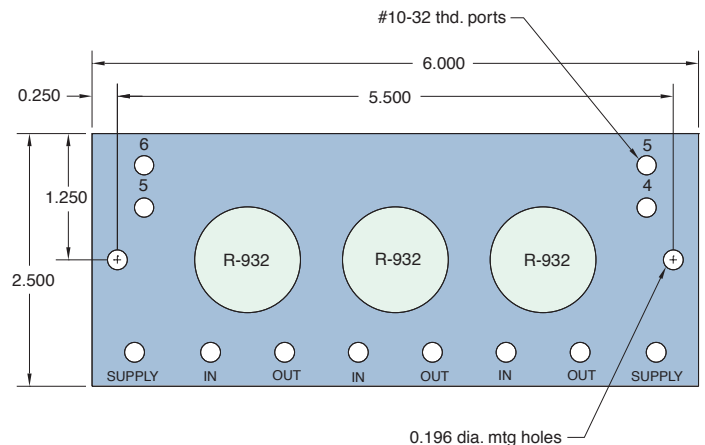

Size: 6" x 2 1/2" x 13/16" thick - 3 modules

Use: 3-valve sequence circuit board used as an expansion unit. #10-32 port connections provided for signal inputs, step outputs, supply and jumper connections for linking multiple boards together. May serve as final segment of circuit or be inserted between two other sequencing subplates.

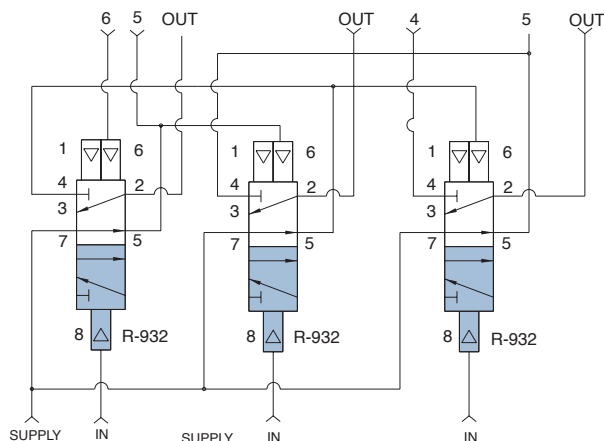

CM-027

Circuit Board for R-932 Sequencing System Using 1 Modular Valve

Size: 2 3/4" x 2 1/2" x 9/16" thick - 1 module
Use: Single valve sequence circuit board used as an expansion unit. #10-32 port connections provided for signal inputs, step outputs, supply and jumper connections for linking multiple boards together. May serve as final segment of circuit or be inserted between two other sequencing subplates.

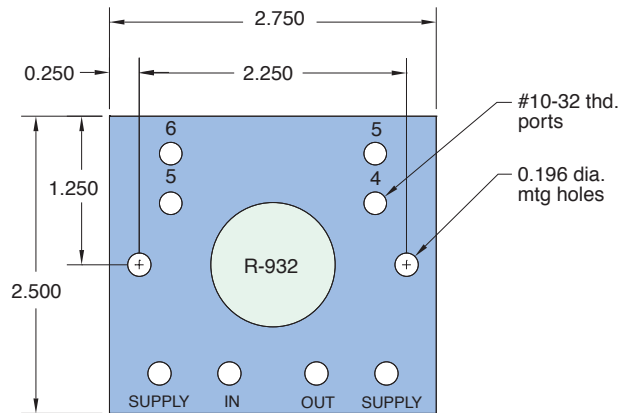
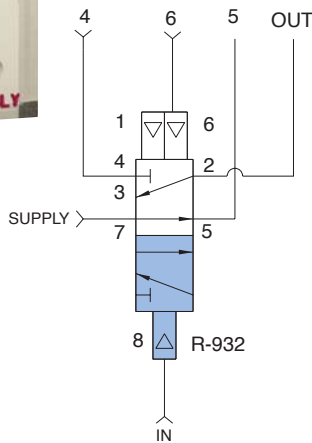

CM-028

Circuit Board For Autocycling of Double Acting Cylinder

Size: 4 1/4" x 2 3/4" x 9/16" thick - 2 modules
Use: For automatic cycling of double acting cylinders without the use of limit valves or magnetic sensors.

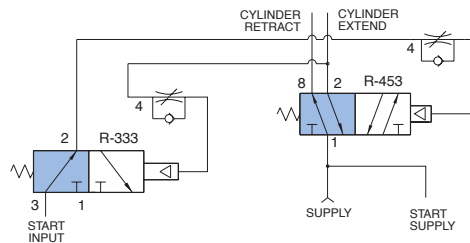

Operation: With no start input, turning supply air on will produce output from cylinder retract (port 8) of R-453. Sending signal to start input passes through normally open R-333, ports 3 to 2, and is metered through flow control circuit of R-453 shifts output to cylinder extend (port 2). This also sends air to the flow control circuit of the R-333 which meters air into the pilot port of the R-333. When sufficient pilot pressure is reached, the R-333 closes allowing port 4 of R-453 to exhaust, thereby shifting output of the valve back to cylinder retract. Adjustment of the respective needle valves allows individual frequency control of extend and retract strokes.

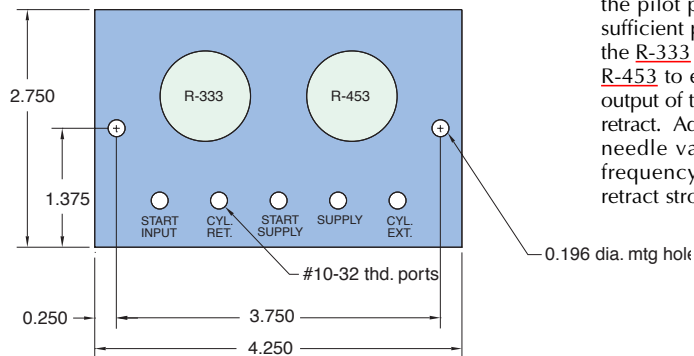



STANDARD PNEUMATIC CIRCUIT BOARDS

CM-030

Back Pressure Sensing for Double Acting Cylinders

Size: 4 1/4" x 3" x 13/16" thick - 2 modules



Use: Highly versatile autocycler manifold for use as an accessory to an R-932 sequencer manifold to accomplish a cycling subroutine.

Operation: When supply air is first turned on, the "memory" feature of R-412 shifts output to port 8 for known starting point. When port 4 of R-355 allows air to flow from port 1 to 2 providing a signal at output (-) port. This output may be used to signal an R-932 sequencer that a step has been completed or the signal may be looped directly back into the input (+) port. This will pilot port 4 of the R-412 shifting the valve output to port 2 giving cylinder + output. As the cylinder reaches full extension, back pressure to port 6 of the R-355 decays allowing output from port 8 of that valve. This output may be used to signal an R-932 sequencer that a step has been completed or may be looped directly back into the input (-) port to repeat the cycle. Cylinder exhaust ports are provided in the manifold in 1/8" NPT to facilitate use of needle valves for speed control.

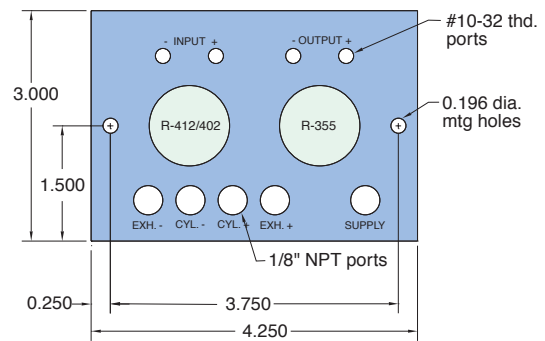
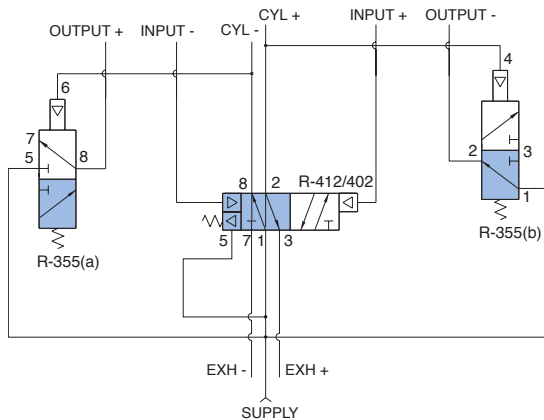

CM-031

Back Pressure Sensing for Double Acting Cylinder

Size: 6" x 3 1/4" x 13/16" thick -3 modules

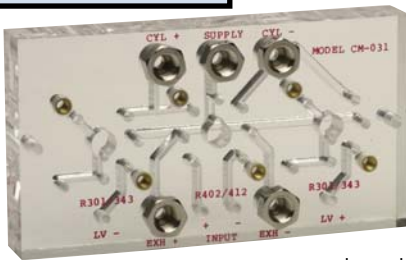

Use: This is a new version of cycling without limits. The system interfaces with the sequencing system using R-932 modular valves. From this operation, you can go back to input the next sequencing function. This is cycling with back pressure, which also has a sensing option, and delay.

Operation: The CM-030 and CM-031 are back pressure sensing circuits similar to the CM-017 and CM-06. The circuits are identical in that they both use a power valve for directional control and two normally open 3-way valves in one body (R-355) while the CM-031 provides additional control options because it uses three valves. The output signal and pilot input signals are externally available. This allows for additional control options and interfaces without 932 sequence control system. With the cylinder at rest in the retracted position air pressure from port 8 of the power valve (R-402 or R-412) is directed to the rod end of the cylinder. It is also referenced to the pilot port of a normally open 3-way (b) maintaining

that valve closed. At this time there is an output at the - output port which comes from the working port of the other normally open 3-way valve (a). Connecting this output to the + input will shift the power valve, sending pressure to the cap end of the cylinder and allowing air to exhaust from the rod end. The air going to the cap end also pilots the 3-way valve (a), which cancels the pilot signal to the power valve. While the cylinder is extending, a back pressure decays allowing that valve (b) to open, producing a signal at the + output port. Connecting this port to the - input will pilot port 6 of the power valve and cause the cylinder to retract. This pressure will turn off valve (b) and the back pressure at the cap end of the cylinder keeps valve (a) closed. The CM-031 requires a separate valve at (a) and (b) but offers additional versatility because a time delay can be incorporated by using our R-341 module and using module R-305 maximizes the pressure differential across the piston. Access to the power valve pilot ports (+ and - inputs) and the + and - outputs enables these circuit boards to be used with the 932 sequence control in applications where it is not convenient to mount limit valves. These controls can also be used to sequence several operations by adding 1 or 2 more valves.

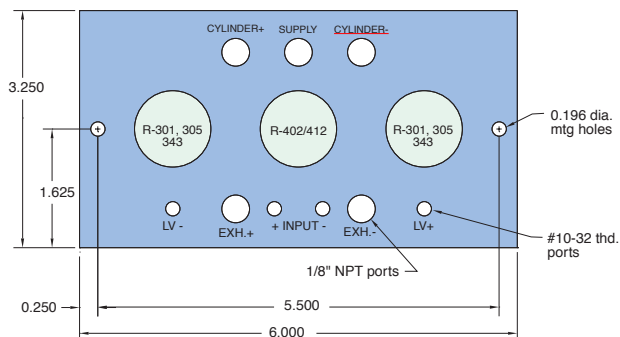
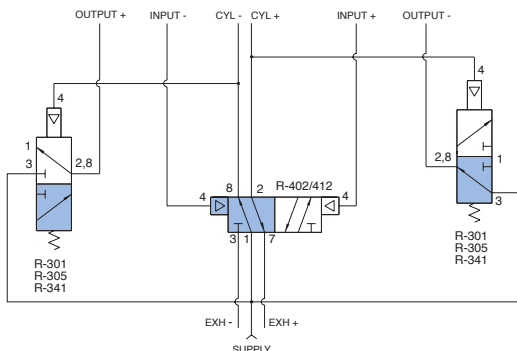

CM-033

Cycling Without Limits with External Power Valve

Size: 6" x 2 3/4" x 9/16" thick - 3 modules



Use: When cycling without limits function is desired from cylinder with bore or stroke requiring very high flow rates to achieve desired cycle speed.

Operation: Similar to CM-06 except output of R-402 is used to pilot a larger pneumatically piloted power valve. Operates as either a straight back pressure sensing system or the use of an R-341 will provide time delay after pressure decay.

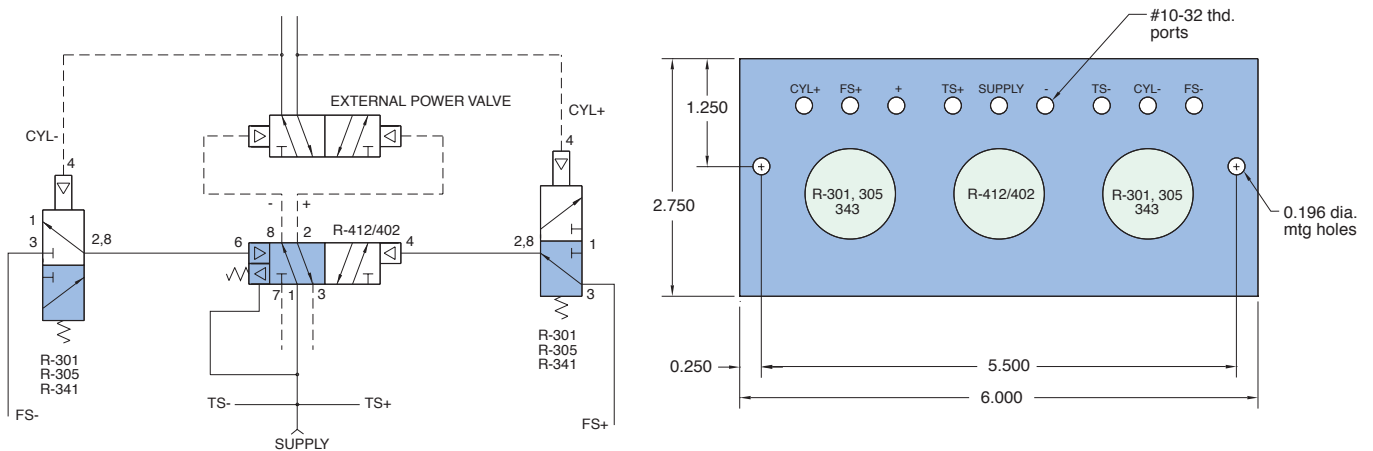

CM-034

Subplate for Back Pressure Latched with Clamp Operated with CM-023

Size: 4 1/4" x 2 1/2" x 13/16" thick - 2 modules

Use: For operation of a clamp or collet system where two hand no tie down input is required to be held continuously until clamp is fully engaged. Two hand not tie down circuit is reengaged to release the clamp mechanism.

Operation: Output of the CM-023 goes to port 1 or R-431 (a). This provides output at port 8 which latches in port 6 and port 5 of R-431 (b). R-431 (b) output shifts to port 2 giving clamp close output and also gives output to LV supply. The CM-023 must remain actuated until the valve is actuated or the spring on the R-431 will return both valves to the clamp open position. When the clamp has fully closed the limit valve is actuated and its output enters at limit input piloting ports 4 of both R-431 (a) and (b). This now latches both valves in the clamp closed position. A new input from the CM-023 now sends a signal from port 1 through port 2 of R-431 (a) which latches port 5 of R-431 (a) and pilots port 6 of R-431 (b). Power output from (b) now shifts to port 8 to unclamp. When the CM-023 palm buttons are released, both valves return to the starting position as shown and the circuit is ready for another operation.

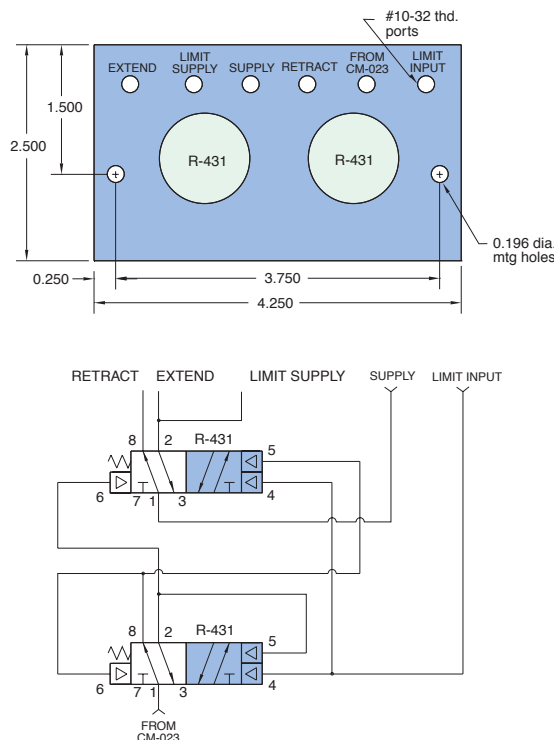



STANDARD PNEUMATIC CIRCUIT BOARDS

CM-035

Circuit Board for R-932 Sequencing System
Using 4 Modular Valves

Size: 7 3/4" x 2 1/2" x 13/16" thick -
4 modules



Use: 4-valve sequence circuit board used as an expansion unit. #10-32 port connections provided for signal inputs, step outputs, supply and jumper connections for linking multiple boards together. May serve as final segment of circuit or be inserted between other sequencing circuit board.

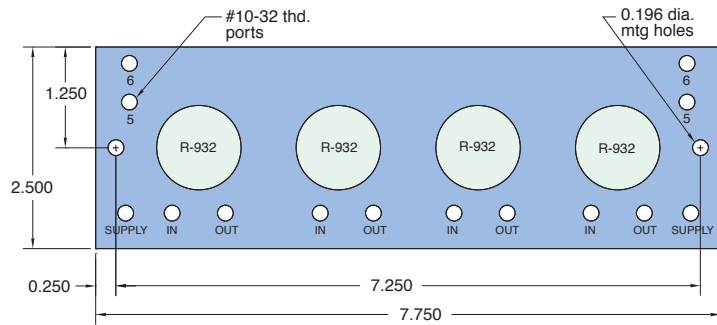
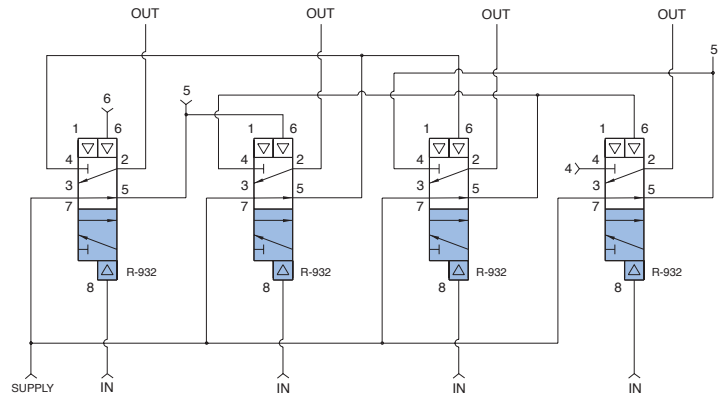

CM-036

2-Valve Mounting Subplate with 1/8" Ports

Size: 7" x 3" x 5/8" thick - 2 modules

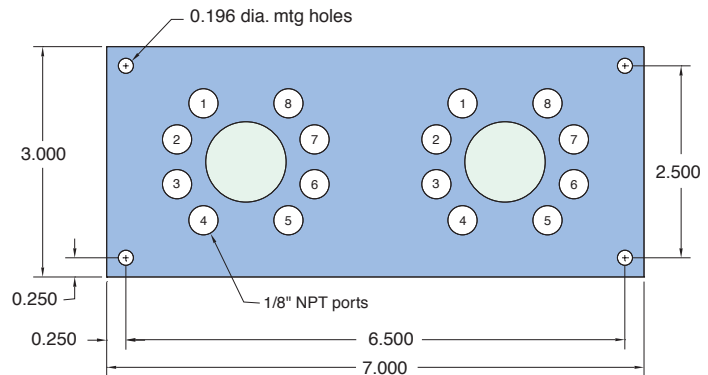

CM-037

3-Valve Mounting Subplate with 1/8" Ports

Size: 10 3/4" x 3" x 5/8" thick - 3 modules

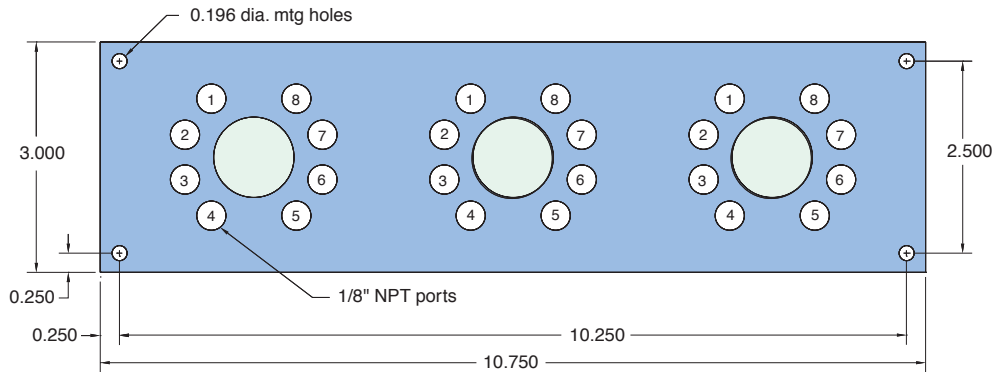

CM-038

2 Hand No Tie Down Circuit with Latching Output

Size: 6" x 4 1/2" x 13/16" thick - 5 modules

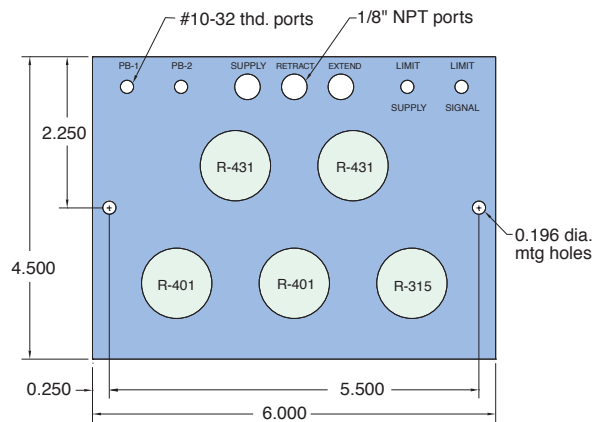
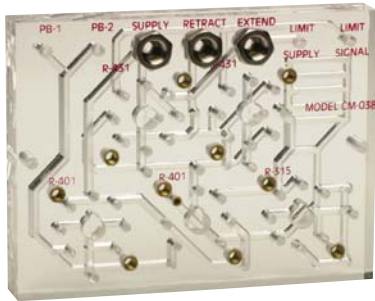

Operation: The CM-038 combines the functions of the [CM-023](#) two hand no tie down with the [CM-034](#) latching circuit. This control requires that the operator push both palm buttons simultaneously and maintain contact until the work member contacts a limit valve*. If the operator removes either hand prior to the limit valve being contacted, the cylinder will return to the home position. Once the limit valve is contacted, the cylinder will remain in place with out the need for operator contact. In order to return to the home position, the operator must depress both buttons simultaneously.

*A back pressure sensing circuit can be used in lieu of a limit valve in applications where it is not practical to mount a limit valve. For more details see [CM-023](#) and [CM-034](#) or consult factory.

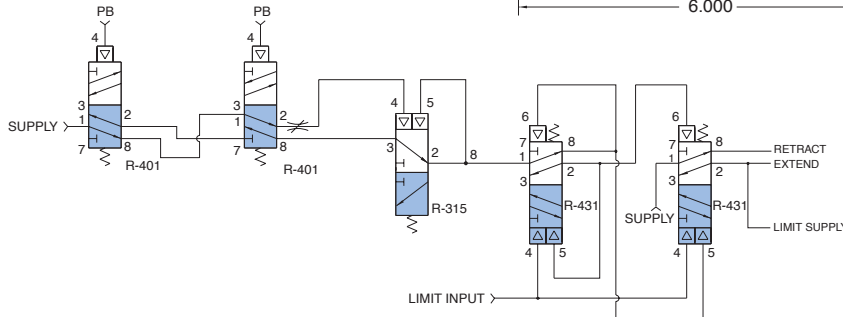

Pneumatic Clamping Circuit Application

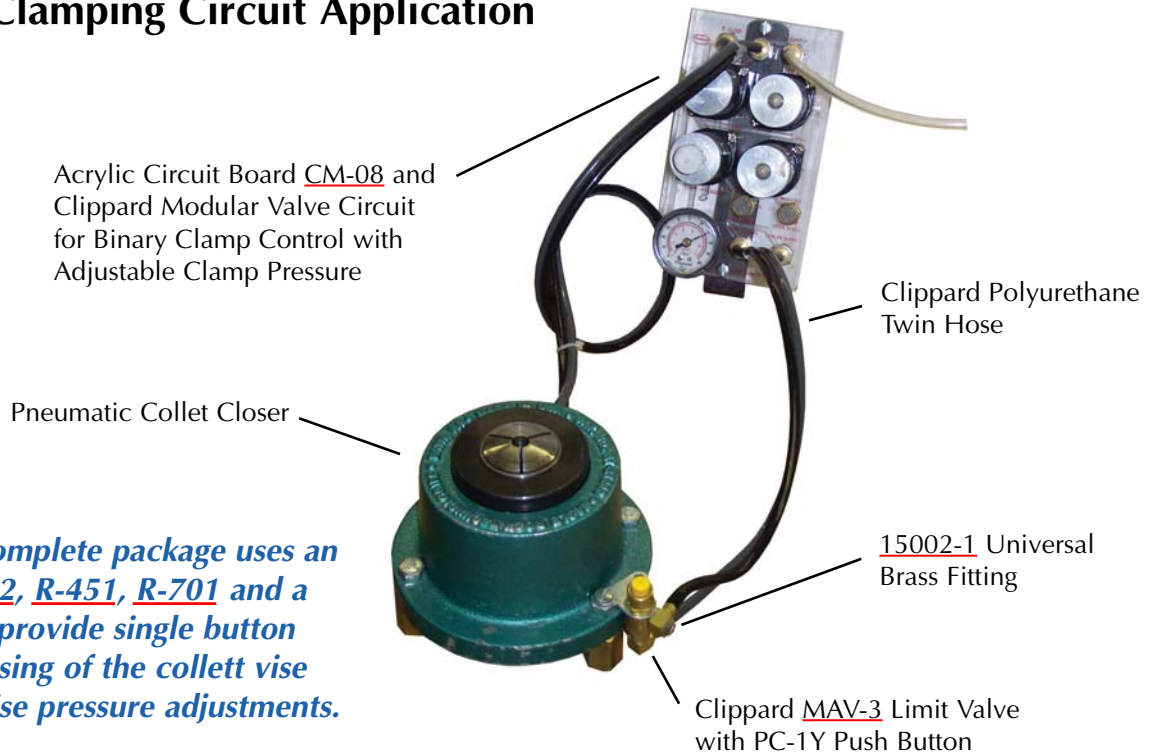

This CM-08 complete package uses an R-401, R-412, R-451, R-701 and a PG-100 to provide single button opening/closing of the collett vise allowing precise pressure adjustments.

Custom Pneumatic Circuit Boards Special Features

Clippard pneumatic circuit boards can be custom-made. Once established, you can depend on your circuit's interconnections to be identical every time.

Component identification is silk-screened on the acrylic board surface for convenience. Each input, output and modular valve is identified to assure proper assembly. Completed circuits may be visually inspected to confirm proper component placement.

Every circuit board uses the exclusive (patented) Clippard "octoport" system to provide standard porting as pioneered throughout Clippard modular valves. Valves are held snugly to the circuit board by two captivated screws furnished with each modular valve. Valve module mounting screw holes are threaded brass inserts for extra strength. Changing valves takes less than a minute. Any valve module may be easily removed without disturbing the other modules, or affecting the circuit interconnections. Use any number of Clippard plug-in valves and controls.

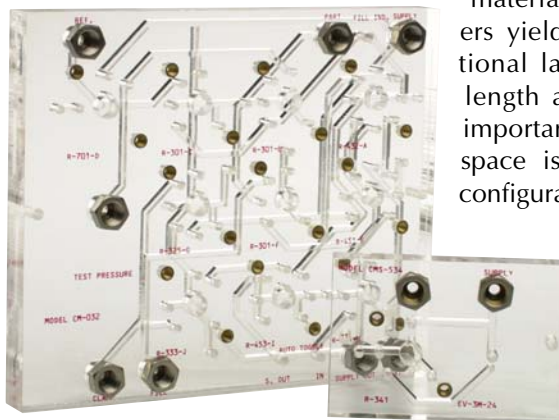

Sophisticated pneumatic circuitry becomes simple to assemble and install using custom pneumatic circuit boards.

Thickness of the pneumatic circuit board subplate is determined by circuit complexity. Greater number of interconnection crossovers requires additional layers of material. The lowest number of plastic layers yields the lowest cost. However, additional layers may be utilized to minimize length and width of the circuit board, an important consideration where mounting space is restricted. Standard circuit board configuration is with all components and connections on the top of the circuit board.

In addition to Clippard modular control valves, the Clippard EV and ET series of electronic interface valves may be mounted on the circuit boards to function as a part of the control circuit. These electronic valves are actuated by 6, 12, & 24 VDC, drawing a low 0.67 watts. They are cool running and fast acting.